

INSTRUCTION MANUAL

700178M

INTEGRATED PRESSURE SENSE CONTROL

MICROPROCESSOR BASED
Integrated Pressure Sense Control Systems

Wiring Diagram 421417 Series

ENTRON

ENTRON Controls, LLC.
601 High Tech Court
Greer, South Carolina 29650
(864) 416-0190
FAX: (864) 416-0195
www.entroncontrols.com

RWMA[®]
MEMBER

THIS PAGE IS
INTENTIONALLY
BLANK

ENTRON Controls, LLC.

INTEGRATED PRESSURE SENSE CONTROL SYSTEMS

INSTALLATION AND OPERATION MANUAL FOR:
IPSC Option for EN1000 Series Weld Controls

| |
|---|
| ! CAUTION ! |
| READ THIS MANUAL COMPLETELY BEFORE ATTEMPTING TO INSTALL OR OPERATE THIS CONTROL |

| |
|---|
| ! WARNING |
|  |
| HAZARDOUS VOLTAGE FROM ONE OR MORE SOURCES Turn off all voltage sources before entering cabinet. Electrical shock or flash may cause severe injury or death. <small>Do not remove or cover this sign. 460146B</small> |

| |
|--|
| ! WARNING |
|  |
| STORED ENERGY/ PRESSURE HAZARD Relieve stored pressure before servicing system. Uncontrolled release of stored energy may cause severe injury or death. <small>Do not remove or cover this sign. 460199A</small> |

| |
|--|
| ! WARNING ! |
| TURN PRESSURE OFF AND BLEED SYSTEM BEFORE ATTEMPTING TO INSTALL OR SERVICE THIS CONTROL BLOCK ALL MOVING DEVICES BEFORE INSTALLATION |

ENTRON Controls, LLC., reserves the right to alter the contents of this manual without previous notice.

ENTRON Controls, LLC.
Greer, South Carolina 29650

TABLE OF CONTENTS

| | | |
|-------|---|----|
| 1.0 | INTRODUCTION | 7 |
| 1.1 | SETTING INDIVIDUAL PRESSURE OR FORCE OR CURRENT | 8 |
| 1.2 | PRESSURE SENSOR AND REGULATOR | 8 |
| 2.0 | AVAILABLE CONFIGURATIONS | 9 |
| 2.1 | INTEGRATED PRESSURE SENSE AND CONTROL | 9 |
| 2.2 | INTEGRATED PRESSURE CONTROL | 9 |
| 2.3 | INTEGRATED PRESSURE SENSE | 10 |
| 3.0 | PROGRAMMING | 10 |
| 3.1 | EXTENDED FUNCTION PROGRAMMING | 10 |
| 3.2 | PRESSURE MODE | 11 |
| 3.2.1 | TRIGGER ON RISING EDGE OF SENSED PRESSURE | 13 |
| 3.2.2 | TRIGGER ON FALLING EDGE OF SENSED PRESSURE | 13 |
| 3.3 | FORCE MODE | 13 |
| 3.3.1 | TRIGGER ON RISING EDGE OF SENSED FORCE | 14 |
| 3.3.2 | TRIGGER ON FALLING EDGE OF SENSED FORCE | 15 |
| 3.4 | CURRENT MODE | 15 |
| 3.4.1 | TRIGGER ON RISING EDGE OF SENSED CURRENT | 15 |
| 3.4.2 | TRIGGER ON FALLING EDGE OF SENSED CURRENT | 15 |
| 3.5 | IPSC SYSTEM ERROR CONDITIONS | 16 |
| 3.6 | PROCESS OUTPUT PROGRAMMING | 17 |
| 4.0 | FIELD INSTALLATIONS | 17 |
| 4.1 | FUSING | 17 |
| 5.0 | PRESSURE REGULATOR | 17 |
| 5.1 | REGULATOR PLACEMENT | 18 |
| 5.2 | REGULATOR ELECTRICAL INTERFACE | 19 |
| 5.3 | OILER PLACEMENT RECOMMENDATIONS | 20 |
| 6.0 | PRESSURE SENSOR | 20 |
| 6.1 | SENSOR PLACEMENT | 20 |
| 6.1.1 | SENSOR PLACEMENT AT TOP OF THE CYLINDER | 21 |
| 6.1.2 | SENSOR PLACEMENT AT BOTTOM OF THE CYLINDER | 21 |
| 6.1.3 | SENSOR PLACEMENT ON THE INPUT AIR LINE | 21 |
| 6.2 | DIFFERENTIAL PRESSURE SENSOR | 21 |
| 6.3 | SENSOR ELECTRICAL INTERFACE | 22 |
| 7.0 | PRODUCT SPECIFICATIONS | 23 |
| 7.1 | PRESSURE REGULATOR WITH VOLUME BOOSTER AND FILTER | 23 |
| 7.2 | SINGLE INPUT PRESSURE SENSORS | 23 |
| 7.2.1 | PRESSURE SENSOR Available after 8/02 | 23 |
| 7.2.2 | OBSELETE – PRESSURE SENSOR Available since 11/97 | 24 |
| 7.3 | DIFFERENTIAL PRESSURE SENSOR | 24 |
| 7.4 | CUSTOMER PROVIDED HARDWARE WIRING | 25 |
| 7.5 | SINKING/SOURCING BLOCK DIAGRAM | 26 |
| 8.0 | TROUBLESHOOTING | 27 |
| 8.1 | INTEGRATED PRESSURE SENSE & CONTROL BLOCK DIAGRAM | 28 |
| 9.0 | IPSC RETROFIT KIT BILL OF MATERIALS | 29 |
| 9.1 | FIELD INSTALLATION OF RETROFIT IPSC OPTION | 31 |

TABLE OF CONTENTS (cont.)

| | |
|---------------------------------------|----|
| 10.0 WARRANTY AND SERVICE | 32 |
| APPENDIX A ORDERING INFORMATION | 33 |

FIGURES

| | | |
|-------------|--|----|
| FIGURE 1-1 | BLOCK DIAGRAM OF CONTROL & IPSC WITH REGULATOR & SENSOR | 7 |
| FIGURE 1-2 | IPSC BOARD | 7 |
| FIGURE 3-1 | SEQUENCE ALGORITHM | 12 |
| FIGURE 5-1 | IPC SYSTEM WITH PRESSURE REGULATOR & MANUAL REGULATOR | 18 |
| FIGURE 5-2 | IPSC SYSTEM WITH REGULATOR & SENSOR IN SINGLE FUNCTION OR CASCADE CONTROL | 19 |
| FIGURE 6-1 | IPS SYSTEM WITH SENSOR | 20 |
| FIGURE 6-2 | DIFFERENTIAL PRESSURE SENSOR | 21 |
| FIGURE 6-3 | IPS SYSTEM WITH DIFFERENTIAL PRESSURE SENSOR | 21 |
| FIGURE 6-4 | DIFFERENTIAL PRESSURE SENSOR LOCATION TO SENSE CYLINDER POSITION | 22 |
| FIGURE 7-1 | REGULATOR, FILTER, VOLUME BOOSTER AND CABLE | 23 |
| FIGURE 7-2 | PRESSURE SENSOR WITHOUT INTEGRAL CABLE | 23 |
| FIGURE 7-3 | SENSOR WITH CABLE | 24 |
| FIGURE 7-4 | DIFFERENTIAL SENSOR | 24 |
| FIGURE 7-5 | IPSC WIRING LOGIC – PROPORTION-AIR | 25 |
| FIGURE 7-6 | IPSC WIRING LOGIC – SMC OR OTHER CUSTOMER PROVIDED CONTROLLER .. | 25 |
| FIGURE 7-7 | 410354-003 SOURCING SENSOR WIRING LOGIC | 25 |
| FIGURE 7-8 | SOURCING SENSOR JUMPER DETAIL | 25 |
| FIGURE 7-9 | 410354-003 SINKING SENSOR WIRING LOGIC | 26 |
| FIGURE 7-10 | SINKING SENSOR JUMPER DETAIL | 26 |
| FIGURE 7-11 | SINKING/SOURCING BLOCK DIAGRAM | 26 |
| FIGURE 8-1 | IPSC BLOCK DIAGRAM | 28 |
| FIGURE 9-1 | IPSC MOUNTING DIAGRAMS | 31 |

TABLES

| | | |
|-----------|------------------------------------|----|
| TABLE 2-1 | IPSC CONFIGURATIONS | 9 |
| TABLE 3-1 | PRESSURE CONTROL PROGRAMMING | 10 |
| TABLE 3-2 | PRESSURE PARAMETERS | 11 |
| TABLE 3-3 | FORCE PARAMETERS | 13 |
| TABLE 3-4 | CURRENT PARAMETERS | 15 |

THIS PAGE IS
INTENTIONALLY
BLANK

1.0 INTRODUCTION

The Integrated Pressure Sense Control System (**IPSC**) is an optional system which may be included with most EN1000 Series Weld Controls. The system is designed so that all the programming is done within the weld control using the Front Panel. The IPSC is in fact an interface between EN1000 Series Weld Control and Pressure Sensor and Regulator.

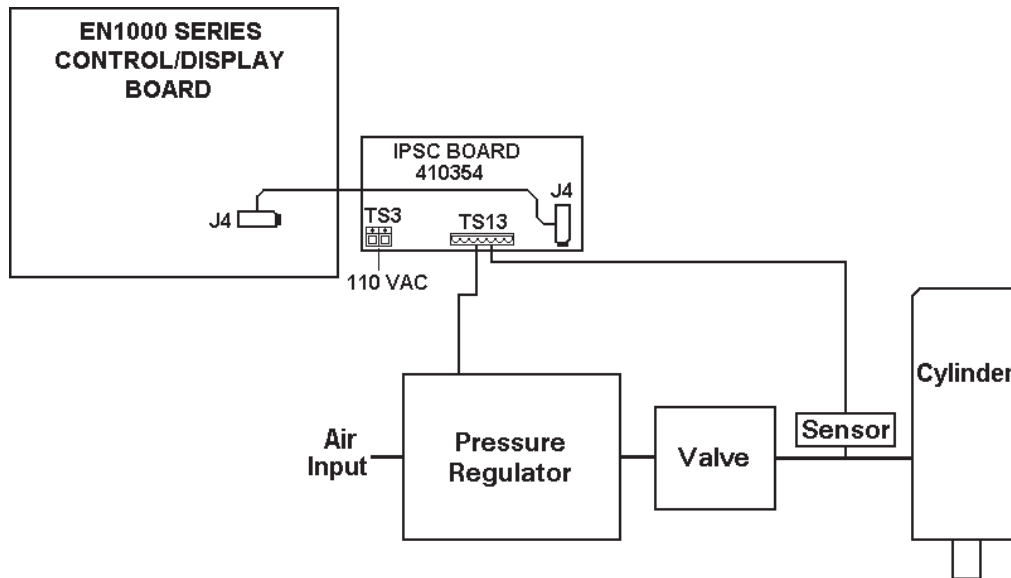

Figure 1-1. Block diagram of Control and IPSC with Regulator and Sensor

The Integrated Pressure Sense Control System is designed for any application that requires automatic selection of a pre-programmed pressure, or automatic switching between different pressure settings. Weld control schedules may be chained to obtain sequential pressure changes. The benefits of the system depend on the application. The ENTRON **IPSC** System allows for sequencing of multiple pressures with one initiation. The flexibility of operation is only limited by the number of weld schedules. An **IPSC** System may be used to remove the worry of pressure settings from the operator. Also, the **IPSC** System may be used to reduce electrode wear by programming “soft set-down” during SQUEEZE. The **IPSC** System may eliminate multiple valves to simplify forging operations. Another application may serve to eliminate many valves when multiple pressures are required for selecting different pressure regulators.

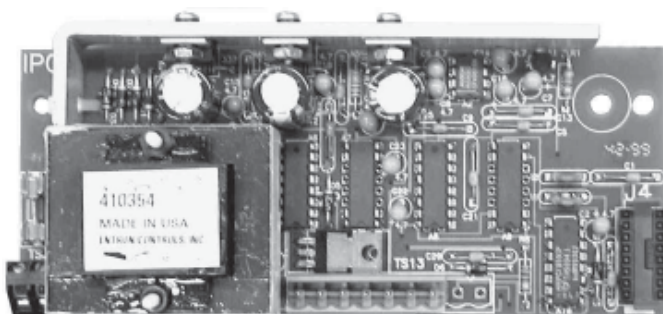

Figure 1-2. IPSC Board

There are three options:

- **IPSC** - Pressure Sense and Control
- **IPC** - Pressure Control
- **IPS*** - Pressure Sense

For **IPSC** and **IPS** options, there are two programmable triggers to continue the sequence after SQUEEZE:

- on rising edge
- on falling edge

* Sensor can be provided as a Differential type, see Section 6.2

1.0 INTRODUCTION (cont.)

There are three programmable modes for any of the three options:

- PRESSURE in [PSI] – input and/or output from 00 to 99 PSI
- FORCE in [lb] – input and/or output from 0000 to 9999 lb
- CURRENT in [mA] – standard industrial input and/or output from 04.00 to 20.00 mA

Pressure Sensor (transducer) has a standard 4.00-20.00 mA output, for 0-100 PSI. Pressure Regulator (complete closed loop servo system) has a standard input 4.00-20.00 mA for 0-100 PSI. Similar devices may be substituted.

1.1 SETTING INDIVIDUAL PRESSURE OR FORCE OR CURRENT

The EN1001 Series Weld Controls with Control Board Assembly No. 600572 with PROM firmware version 619016-001R or later, and IPSC Hardware Board Assembly No. 410354, can be programmed to sense and/or control **PRESSURE** or **FORCE** or **CURRENT**. Upon system initialization, the weld control will detect IPSC hardware. If the IPSC hardware exists, a new EXTENDED FUNCTION parameter **P.C.** (PRESSURE CONTROL) will be available. Depending on the programmed value in **P.C.**, the control will allow individual PRESSURE or FORCE or CURRENT to be programmed into the control for any schedule. See the appropriate Instruction Manual and Application Note for complete control programming instructions.

1.2 PRESSURE SENSOR* AND REGULATOR

An ENTRON Integrated Pressure System may include a Pressure transducer (**Sensor**) in **IPSC** and **IPS** options, and/or an electro-pneumatic servo valve (**Regulator**) in **IPSC** and **IPC** options.

The Pressure Sensor accurately measures air pressure and converts the measurement to an electrical signal. The electrical output is a linear ratio of the sensed pressure. The Sensor is connected to the IPSC Board through TS13. The signal from the Sensor is converted by the IPSC Board and data is sent to the weld Control Board.

The Regulator with a filter and volume booster is installed in the pneumatic system typically replacing the manual regulator. It regulates the air pressure based on the programmed PRESSURE. The Regulator is electro-pneumatic closed loop servo system consisting of valves, manifold, housing and electronic components. The output pressure is controlled by an electrical input signal. This Regulator interfaces with the IPSC Board through the TS13-J13 Cable Assembly (P/N 326039). Data from the weld Control Board is received by the IPSC Board and converted to the command signal for the Regulator. The Regulator is equipped with an internal feedback loop which compensates for variations of incoming pressure providing highly accurate pressure control.

Since the Regulator is a servo system with an internal feedback loop, the Sensor in the **IPSC** and **IPS** Systems can be used to feedback pressure values to the control to confirm that a command (required) pressure is available in one of the three alternative locations for the Pressure Sensor: the incoming air line to the machine, the air line into the cylinder, or the exhaust side of the cylinder.

* Sensor can be provided as a Differential type, see Section 6.2

1.2 PRESSURE SENSOR* AND REGULATOR (cont.)

The weld control including an **IPSC** System with Sensor and Regulator can be used for pressure sense and control in other non-resistance welding operations such as: dispensing, moving, checking vacuum on lifter, checking pressure in reservoir and water pressure, etc. When using these features along with **CHAINED** and **SUCCESSIVE CYCLE MODE**, special functions can be accomplished using standard controls.

2.0 AVAILABLE CONFIGURATIONS

The **ENTRON** Integrated Pressure Sense Control Systems may be configured to allow great flexibility in many applications. Table 2-1 shows all possible configurations.

Table 2-1. *IPSC configurations*

| Model Option | Description |
|--------------|---|
| IPSC2 | Integrated Pressure Sense and Control, 1/2" Ports |
| IPSC5 | Integrated Pressure Sense and Control, 1 1/4" Ports |
| IPC2 | Integrated Pressure Control Only, 1/2" Ports |
| IPC5 | Integrated Pressure Control Only, 1 1/4" Ports |
| IPS | Integrated Pressure Sense Only |

2.1 INTEGRATED PRESSURE SENSE* AND CONTROL

Example: EN1000-600/IPSC5 includes Assembly P/N 410354 (or 410354-004)

Allows programming of any **PRESSURE/FORCE/CURRENT** setting within any schedule of the weld control (see Section 2.2). In addition, it allows sensing or measuring **PRESSURE/FORCE/CURRENT** and display of measured values (see Section 2.3). P/N 410354-004 is available for applications that require the use of sourcing sensors (Figures 7-7, 7-8 and 7-11).

2.2 INTEGRATED PRESSURE CONTROL

Example: EN1000-600E/IPC2 includes Assembly P/N 410354-001

Allows programming of any **PRESSURE/FORCE/CURRENT** setting within any schedule of the weld control. In a weld control that allows programming 50 (or 100) schedules, the control can accept 50 (or 100) different **PRESSURE/FORCE/CURRENT** settings. The **PRESSURE** settings become active during the execution of the **SQUEEZE** time of the weld schedule. The **IPC** System with a Pressure Regulator is a complete closed loop servo system with an internal feedback. For normal operation it does not require a Pressure Sensor. Weld controls with this option (e.g., EN1000-600T/IPC2) provide only pressure control without pressure sense or display of measured values.

* Sensor can be provided as a Differential type, see Section 6.2

2.3 INTEGRATED PRESSURE SENSE*

Example: EN1000-600E/IPS includes Assembly P/N 410354-002 (or 410354-003)

Allows sensing and display of a separate, user defined, PRESSURE/FORCE/CURRENT. The IPS System can be configured to trigger on a RISING or FALLING PRESSURE. RISING or FALLING PRESSURE triggering is determined by programmed EXTENDED FUNCTION parameter **P.C.**. The IPS with Pressure Sensor is an independent system and does not require the Pressure Regulator to operate. A weld control with this option (e.g., EN1000-600E/IPS) provides only pressure sensing without pressure control. P/N 410354-003 is available for applications that require the use of sourcing sensors (Figures 7-7, 7-8 and 7-11).

Since the sensed pressure is read directly by the weld control, it is the basis for pressure triggering during the sequence. The pressure sense is commonly used to determine if a programmed pressure has been reached before the WELD portion of a weld sequence. It can be used to determine when to trigger a weld if pressure is reached during a pressure transition. It can be used to emulate a pressure switch used to trigger the weld upon reaching a minimum pressure. In addition, the pressure switch could also be used to determine whether exhaust side of cylinder is completely evacuated by allowing triggering on a lack of pressure (very low) or a low value of pressure.

3.0 PROGRAMMING

3.1 EXTENDED FUNCTION PROGRAMMING

If an IPSC Board exists, the weld control will add the following parameters to the EXTENDED FUNCTIONS: **P.C.**, **b.d.**, and **S.I.**

PRESSURE CONTROL P.C. – This parameter activates any pressure sense control mode.

1. Click the SELECT push button until **EF** appears in the DATA display.
2. Press the SCHEDULE push buttons to find **P.C.** in the SCHEDULE display.
3. Program the required values according to Table 3-1.

Table 3-1. PRESSURE CONTROL programming

| P.C. | Trigger | Mode |
|-------------|--------------|----------------------------------|
| 00 | — | NO Pressure Sense and/or Control |
| 01 | rising edge | PRESSURE in [PSI] |
| 02 | falling edge | |
| 03 | rising edge | FORCE in [lb] |
| 04 | falling edge | |
| 05 | rising edge | CURRENT in [mA] |
| 06 | falling edge | |

4. Press ENTER push button.
5. If the IPSC mode is FORCE mode, **P.C.=03** or **04**, the control will display an additional set of parameters, **d i** (diameter), after the EXTENDED FUNCTIONS. If this is the case, up to 4 independent diameters may be programmed.
 - a) Click SELECT to find the **d i** set of parameters. (Click once past SLOPE COUNT to show **EF**, then click once more to show **d i**.)
 - b) Press the SCHEDULE push buttons to find **d0**, **d1**, **d2**, or **d3**.
 - c) Program the appropriate diameter in inches. Values from 00.00 to 20.00 inches are only possible values for diameter.

* Sensor can be provided as a Differential type, see Section 6.2

3.1 EXTENDED FUNCTION PROGRAMMING (cont.)

BACKGROUND (RETURN) PRESSURE/FORCE/CURRENT *b.d.* – This parameter is necessary with the **IPSC** and **IPC** System options in order to set the **BACKGROUND (RETURN) PRESSURE/FORCE/CURRENT** required to return cylinder or return working rod. **See Warning in Section 5.1.**

1. Using the **SELECT** push button, find **EXTENDED FUNCTIONS**.
2. Press the **SCHEDULE** push buttons to find ***b.d.*** in the **SCHEDULE** display.
3. Program the required values according to the mode used:
 - b.d.*** = 00 - 99, in **PRESSURE** mode.
 - b.d.*** = 0000 - xxxx, in **FORCE** mode, where xxxx is max force.
 - b.d.*** = 04.00 - 20.00 mA, in **CURRENT** mode.

SENSOR INPUT *5.l.* – This parameter will appear only with the **IPSC** and **IPS** System options to show **PRESSURE/FORCE/CURRENT** input from Pressure Sensor on the **DATA** display. ***5.l.*** is not programmable.

3.2 PRESSURE MODE – *P.C.=01 OR 02*

In this mode, the **PRESSURE** parameters are stored in *pounds per square inch*, [PSI]. This is the simplest and most common way to get familiar with the operation of the **IPSC** Systems. Depending on **IPSC** System option, the following **PRESSURE** parameters are available.

Table 3-2. PRESSURE parameters

| IPSC Option | Extended Schedule parameters | EF parameters |
|-------------|---|--|
| IPSC | <i>P.r.</i> - Pressure Required, <i>P.t.</i> - Pressure Trigger | <i>P.C.</i> , <i>b.d.</i> , <i>5.l.</i> |
| IPC | <i>P.r.</i> - Pressure Required | <i>P.C.</i> , <i>b.d.</i> |
| IPS | <i>P.r.</i> - Pressure Required, <i>P.t.</i> - Pressure Trigger | <i>P.C.</i> , <i>5.l.</i> |

To program the **REQUIRED PRESSURE** or **TRIGGER PRESSURE**:

1. Put the control in **PROGRAM** mode by clicking **PROGRAM/OPERATE** push button.
2. Click the **SELECT** push button to reach the **SQUEEZE** parameter.
3. Program the required **SQUEEZE** time for the weld sequence.

NOTICE

Too high a **SQUEEZE** time may affect trigger operation. Set this value to 0 to continue sequence immediately after **TRIGGER PRESSURE** is reached. During initial setup, when **ERROR 36** occurs, sequence may be aborted using Front Panel **WELD/NO WELD** switch to complete trial settings.

4. Press the **SCHEDULE** push buttons to find ***P.r.*** in the **SCHEDULE** display.
5. Program the required value of **REQUIRED PRESSURE** from 00 to 99 PSI.
6. Press the **SCHEDULE** push buttons to find ***P.t.*** in the **SCHEDULE** display.
7. Program the required value of **TRIGGER PRESSURE** from 00 to 99 PSI.

All **PRESSURE** parameters are programmable in 1 PSI increments.

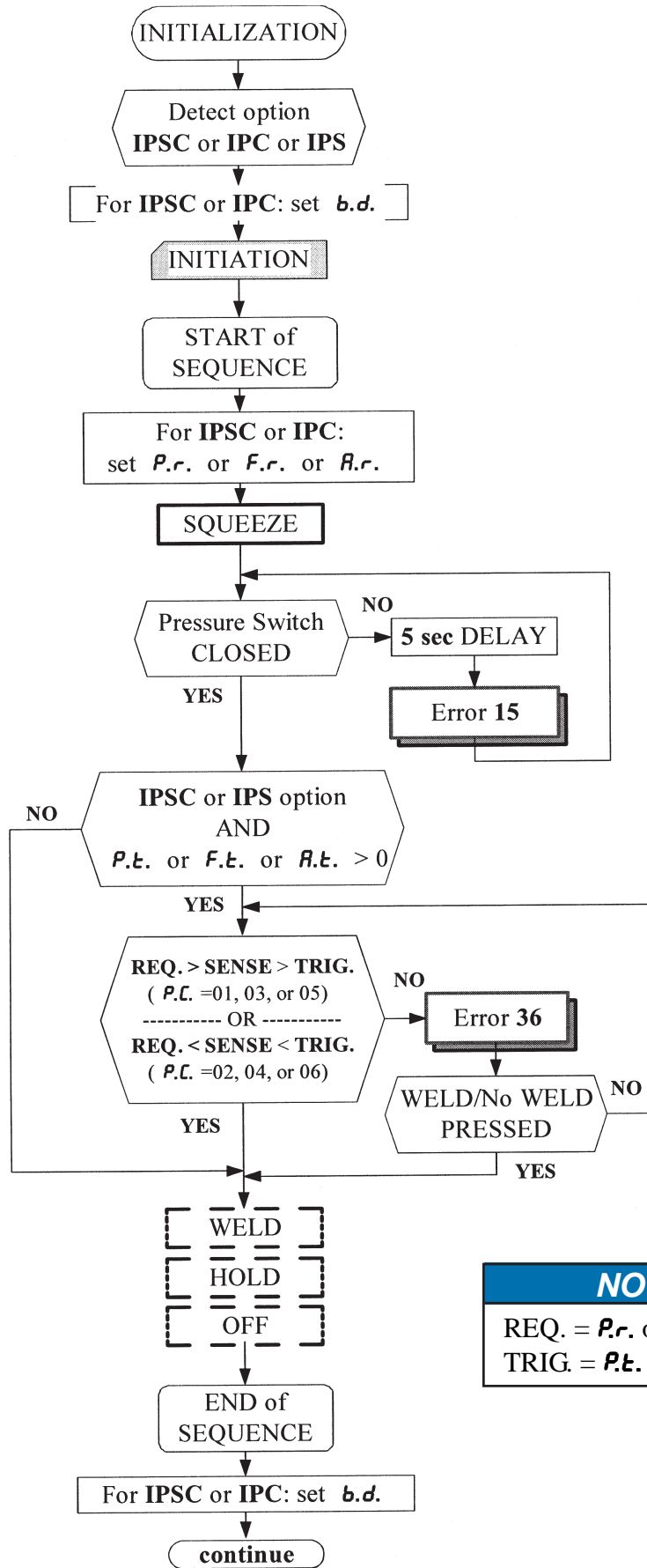

NOTICE
 REQ. = P.r. or F.r. or R.r.
 TRIG. = P.t. or F.t. or R.t.

Figure 3-1. Sequence Algorithm

3.2.1 TRIGGER ON RISING EDGE OF SENSED PRESSURE – P.C.=01

For **IPSC** and **IPC** System options, when weld control is initiated, it will switch, before the programmed SQUEEZE portion of the weld sequence, from BACKGROUND (RETURN) PRESSURE, stored in parameter **b.d.**, to REQUIRED (desired) PRESSURE, stored in parameter **P.r.**. The new PRESSURE value will be set whenever the programmed valve is activated. If the initiated schedule contains more than one valve, it will use this PRESSURE on all active valves.

When the Pressure Sense option is available (**IPSC** and **IPS** System options) and both **P.r.** and **P.t.** are programmed, the weld control compares real pressure from the Sensor with PRESSURE defined in **P.r.**, which is HI or maximum value, and **P.t.** which is LO or minimum value. Programmed value for TRIGGER PRESSURE **must** be less than or equal to REQUIRED PRESSURE (i.e., $P_t \leq P_r$ if $P_r > 0$). When the weld control is initiated, the control will wait until the TRIGGER PRESSURE is reached at the end of the SQUEEZE portion of the weld sequence (i.e., if $P_t \leq P_{\text{sensor}} \leq P_r$), the sequence will be continued (Figure 3-1). The control will not continue the sequence from SQUEEZE to WELD if TRIGGER PRESSURE is not reached or if real pressure is out of the PRESSURE window. This allows for the weld to be started during the **RISING** portion of the pressure curve. Generally used to monitor top chamber of cylinder.

3.2.2 TRIGGER ON FALLING EDGE OF SENSED PRESSURE – P.C.=02

This mode is the same as the previous one, except that TRIGGER PRESSURE **P.t.**, which is now HI or maximum value, **must** be greater than or equal to REQUIRED PRESSURE **P.r.**, which is LO or minimum (i.e., $P_t \geq P_r$, and if $P_r \leq P_{\text{sensor}} \leq P_t$), the sequence will be continued (Figure 3-1). This allows for the weld to be started during the **FALLING** portion of the pressure curve. Generally used to monitor the bottom chamber of the cylinder.

3.3 FORCE MODE – P.C.=03 OR 04

In this mode, the weld control PRESSURE parameters are stored in *pounds*, [lb]. In this mode, the control offers the additional benefit of FORCE regulation and monitoring. This may be very useful, since most welding schedule tables show FORCE as a required elements in a weld schedule. Depending on **IPSC** System option, the following **FORCE** parameters are available.

Table 3-3. FORCE parameters

| IPSC Option | Extended Schedule parameters | EF parameters |
|-------------|---|---|
| IPSC | F.r. - Force Required, F.t. - Force Trigger | P.C. , b.d. , S.I. |
| IPC | F.r. - Force Required | P.C. , b.d. |
| IPS | F.r. - Force Required, F.t. - Force Trigger | P.C. , S.I. |

Before programming any of FORCE parameters, cylinder diameters **must** be programmed as described in Section 3.1.

In addition to the **PRESSURE** mode operation, the weld control may be programmed to work in **FORCE** mode. When the IPSC hardware exists, the control allows for programming up to four cylinder diameters. If FORCE monitoring and/or regulation is required using more than one cylinder, the control allows programming of parameters **D1**, **D2**, and **D3**. These diameters

3.3 FORCE MODE – P.C.=03 OR 04 (cont.)

can only be associated with the independent use of one of the three valves attached to the control. If more than one valve is used in a sequence, the weld control will use the default value stored in **D0**. The valve number in the control corresponds directly to the parameters by number. Valve 1 diameter is stored in D1. Valve 2 diameter is stored in D2, and Valve 3 diameter is stored in D3. The default value is stored in the parameter D0.

The same Pressure Regulator and Sensor are used in this mode, but FORCE is calculated internally, according to the equation:

$$F = P \frac{D^2 \pi}{4}$$

where F - force in [lb], P - pressure in [PSI], D - diameter of cylinder in [inch]

To program the REQUIRED FORCE or TRIGGER FORCE:

1. Put the control in PROGRAM mode by clicking PROGRAM/OPERATE push button.
2. Click the SELECT push button to reach the SQUEEZE parameter.
3. Program the required SQUEEZE time for the weld sequence.

NOTICE

Too high a SQUEEZE time may affect trigger operation. Set this value to 0 to continue sequence immediately after TRIGGER PRESSURE is reached. During initial setup, when ERROR **36** occurs, sequence may be aborted using Front Panel WELD/NO WELD switch to complete trial settings.

4. Press the SCHEDULE push buttons to find **F.r.** in the SCHEDULE display.
5. Program the required value of REQUIRED FORCE from 0000 to 9999 lb.
6. Press the SCHEDULE push buttons to find **F.t.** in the SCHEDULE display.
7. Program the required value of TRIGGER FORCE from 0000 to 9999 lb.

All FORCE parameters are programmable in $(99 \cdot D^2 \cdot \pi / 4) / 255$ lb. increments.

3.3.1 TRIGGER ON RISING EDGE OF SENSED FORCE – P.C.=03

When the weld control is initiated, for **IPSC** and **IPC** System options, the control will switch, before the programmed SQUEEZE portion of the weld sequence, from BACKGROUND (RETURN) FORCE, stored in parameter **b.d.**, to REQUIRED (desired) FORCE, stored in parameter **F.r.**. The new FORCE value will be set whenever the programmed valve is activated. When the Pressure Sense option is available (**IPSC** and **IPS** System options) and both **P.r.** and **P.t.** are programmed, the weld control compares calculated FORCE, based on value from the Sensor, with window defined in **F.r.**, which is HI or maximum value, and **F.t.** which is LO or minimum value. Programmed value for TRIGGER FORCE **must** be less than or equal to REQUIRED FORCE (i.e., $F_t \leq F_r$ if $F_r > 0$). When the weld control is initiated, the control will wait until the TRIGGER FORCE is reached at the end of the SQUEEZE portion of the weld schedule sequence; i.e., until $F_t \leq F_{\text{sensor}} \leq F_r$ (Figure 3-1). The control will not continue the sequence from SQUEEZE to WELD if TRIGGER FORCE is not reached or if real force is out of FORCE window. This allows for the weld to be started during the **RISING** portion of the force curve.

3.3.2 TRIGGER ON FALLING EDGE OF SENSED PRESSURE – P.C.=04

This mode is the same as previous one, except that TRIGGER FORCE **F.t.**, which is now HI or maximum value, **must** be greater than or equal to REQUIRED FORCE **F.r.** which is LO or minimum; i.e., $F_t \geq F_r$, and if $F_r \leq F_{\text{sensor}} \leq F_t$, sequence will be continued (Figure 3-1). This allows for the weld to be started during the **FALLING** portion of the force curve.

3.4 CURRENT MODE – P.C.=05 or 06

In this mode, the weld control PRESSURE parameters are stored in *milliamperes*, [mA]. This mode is most useful for the user who wants to implement the Pressure System using their own hardware, regulator and sensor. It provides full range of control of pressure levels within the industrial standard 4-20 mA range. Depending on IPSC System option, the following **CURRENT** parameters are available.

Table 3-4. CURRENT parameters

| IPSC Option | Extended Schedule parameters | EF parameters |
|-------------|---|---|
| IPSC | R.r. - Required Current, R.t. - Trigger Current | P.C. , b.d. , S.I. |
| IPC | R.r. - Required Current in mA | P.C. , b.d. |
| IPS | R.r. - Required Current, R.t. - Trigger Current | P.C. , S.I. |

The same Pressure Sensor and Regulator may be used in this case, but signal from the Sensor and signal to the Regulator are used directly without conversion in PSI.

To program the REQUIRED CURRENT or TRIGGER CURRENT:

1. Put the control in PROGRAM mode by clicking PROGRAM/OPERATE push button.
2. Click the SELECT push button to reach the SQUEEZE parameter.
3. Program the required SQUEEZE time for the weld sequence.

NOTICE

Too high a SQUEEZE time may affect trigger operation. Set this value to 0 to continue sequence immediately after TRIGGER PRESSURE is reached. During initial setup, when ERROR **36** occurs, sequence may be aborted using Front Panel WELD/NO WELD switch to complete trial settings.

4. Press the SCHEDULE push buttons to find **R.r.** in the SCHEDULE display.
 5. Program the required value of REQUIRED CURRENT from 04.00 to 20.00 mA.
 6. Press the SCHEDULE push buttons to find **R.t.** in the SCHEDULE display.
 7. Program the required value of TRIGGER CURRENT from 04.00 to 20.00 mA.
- All CURRENT parameters are programmable in $1/(255/16)=0.0627$ mA increments.

3.4.1 TRIGGER ON RISING EDGE OF SENSED CURRENT – P.C.=05

This mode is the same as PRESSURE mode with TRIGGER on RISING edge, except that all data is in [mA] instead in [PSI]. See Section 3.2.1 or Section 3.3.1 and Figure 3-1.

3.4.2 TRIGGER ON FALLING EDGE OF SENSED CURRENT – P.C.=06

This mode is the same as PRESSURE mode with TRIGGER on FALLING edge, except that all data is in [mA] instead in [PSI]. See Section 3.2.2 or Section 3.3.2 and Figure 3-1.

3.5 IPSC SYSTEM ERROR CONDITIONS

The EN1000 Series Controls with **IPSC** System option will signal pressure errors for the following conditions.

***E.r.=15* – Pressure Switch is Open**

The control will show ***E.r.=15*** if the pressure switch is open. This is the same ERROR CODE used in weld controls without **IPSC** System options.

This ERROR will be cleared and sequence will be continued when the pressure switch is closed. Another way to clear this ERROR is resetting the control by opening the Emergency Stop switch.

***E.r.=36* – TRIGGER PRESSURE/FORCE/CURRENT is not reached**

When the control has **IPSC** or **IPS** System option, the control will show ***E.r.=36*** under the following conditions:

Real value for PRESSURE/FORCE/CURRENT from Sensor is out of window; i.e., if it is less than TRIGGER or greater than REQUIRED PRESSURE/FORCE/CURRENT in TRIGGER on RISING edge modes – ***P.C.=01, 03, or 05*** for RISING PRESSURE/FORCE/CURRENT detection.

Real value for PRESSURE/FORCE/CURRENT from Sensor is out of window; i.e., if it is less than REQUIRED or greater than TRIGGER PRESSURE/FORCE/CURRENT in TRIGGER on FALLING edge modes – ***P.C.=02, 04, or 06*** for FALLING PRESSURE/FORCE/CURRENT detection.

NOTICE

PRESSURE/FORCE/CURRENT window is defined with REQUIRED and TRIGGER values. If REQUIRED value is not programmed (i.e., equals 0), the control will check only whether or not TRIGGER value is reached in both RISING and FALLING modes.

When TRIGGER PRESSURE/FORCE/CURRENT is reached, this ERROR will be cleared and sequence will be continued only if a Program Lockout Switch (PLS) is not used. If a PLS is used, the sequence will be stopped and ***E.r.=36*** will be displayed until the PLS is turned on. At that point if the SELECT push button is pressed, the sequence will be aborted; if the WELD/NO WELD push button is pressed, the sequence will continue. Another way to clear this ERROR and continue the sequence is to put the control in NO WELD mode, by pressing the WELD/NO WELD push button.

NOTICE

To abort a sequence during ERROR ***36***, put control in NO WELD to complete the sequence in NO WELD. If PLS is used, turn the key and then push the WELD/NO WELD button.

3.6 PROCESS OUTPUT PROGRAMMING

The EN1000 Series Controls with **IPSC** System option provide for programmability of the following additional PROCESS OUTPUTS.

1. Click the SELECT push button until **EF** appears in the DATA display.
2. Press the SCHEDULE push buttons to find **P.O.** in the SCHEDULE display.
3. Program the required values as follows:

P.O.=30 – Valve 3 turns ON whenever ERROR **36** (IPSC or IPS error), occurs.

When the control includes the **IPSC** or **IPS** option, the control may be programmed to indicate whenever any pressure error is detected.

P.O.=31 – Valve 3 ON if ERROR **36** (IPSC or IPS error) occurs immediately after the weld.

When the control includes the **IPSC** or **IPS** option, and while using this PROCESS OUTPUT, the control reads the Sensor output after the WELD portion of weld sequence and turns Valve 3 on if the TRIGGER value for PRESSURE/FORCE/CURRENT is not reached. The TRIGGER values must be programmed within a valid range.

4.0 FIELD INSTALLATIONS

The Integrated Pressure Sense Control System connections are done at the factory. For field retrofits, contact ENTRON to determine availability and instructions.

4.1 FUSING

For the IPSC hardware protection for any of the Integrated Pressure Sense Control System options, a fuse 1/4 A, 2AG (P/N 307023) is included.

5.0 PRESSURE REGULATOR (SERVO CONTROL VALVE)

The Regulator is electro-pneumatic closed loop servo system consisting of valves, manifold, housing and electronic components. The output pressure is controlled by an electrical input signal. This Regulator interfaces with the IPSC or IPC Board through the TS13-J13 Cable Assembly (P/N 326039). Data from the weld Control Board is received by IPSC Board and converted to the command signal for the Regulator. The Regulator is equipped with an internal feedback loop which compensates for variations of incoming pressure providing highly accurate pressure regulation. A volume booster and filter are used also.

Programming PRESSURE parameters for Regulator input and Sensor output display is performed on the weld control. Interface between the weld control and Pressure Regulator and Sensor is the IPSC Board, as shown on the block diagram in Figure 1-1.

5.1 REGULATOR PLACEMENT

Since several configurations are possible, actual Regulator placement in the system is left to the system designer. The IPC System option with one of several possible configuration is shown in Figure 5-1. The system provides monitoring and accurate pressure control, even when variations of line pressure occur. The regulated air creates the force used to press the welding electrodes upon the parts to be welded. A repeatable and constant electrode force during the weld sequence helps achieve consistent weld quality. If the Sense option is available, the weld control may be used to monitor and display pressure. In this case, if pressure loss occurs, it can be viewed directly on the Front Panel display, either as ERROR 36, or directly by selecting the EXTENDED FUNCTION parameter 5.1. The pressure reading depends on location of the Sensor. The IPSC System option with one of several possible configuration is shown in Figure 5-2.

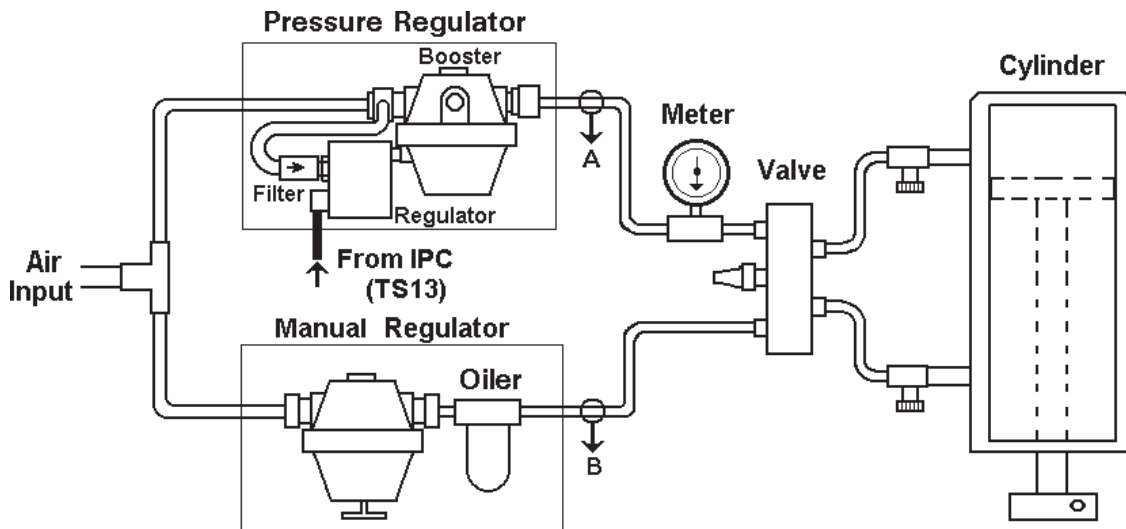

Figure 5-1. IPC System with Pressure Regulator and manual regulator

NOTICE

When regulation is used on Cascade controls or weld controls with multiple valves, points A & B can be tied to more valves and cylinders.

However, in most applications, using a manual regulator is necessary to feed the return chamber of the air cylinder (Figure 5-1). The manual regulator is used to assure that the weld head will stay in upper position at the end of sequence even when power to the control or IPSC Board is off. In this case, background (return) pressure is controlled with manual regulator and value programmed in the parameter **b.d.** will not have any effect on the background (return) pressure.

In some resistance welding applications, the Regulator may be placed to feed both top and bottom chamber of the air cylinder (Figure 5-2). If the regulator is placed so that it controls both the top and bottom of the cylinder as shown in Figure 5-2, the background (return) pressure is controlled also with the same pressure regulator and the value programmed in parameter **b.d.** will be used to set the BACKGROUND (RETURN) PRESSURE. Program **b.d.** with sufficient PRESSURE to raise the electrodes (cylinder). After end of sequence, the air creates the force for return weld head in top position. While the weld control power is on, the Regulator maintains the system pressure continuously based on the programmed PRESSURE setting. If the available line pressure drops below the programmed REQUIRED PRESSURE **P.r.**, the Regulator cannot compensate. See **WARNING** on next page.

5.1 REGULATOR PLACEMENT (cont.)

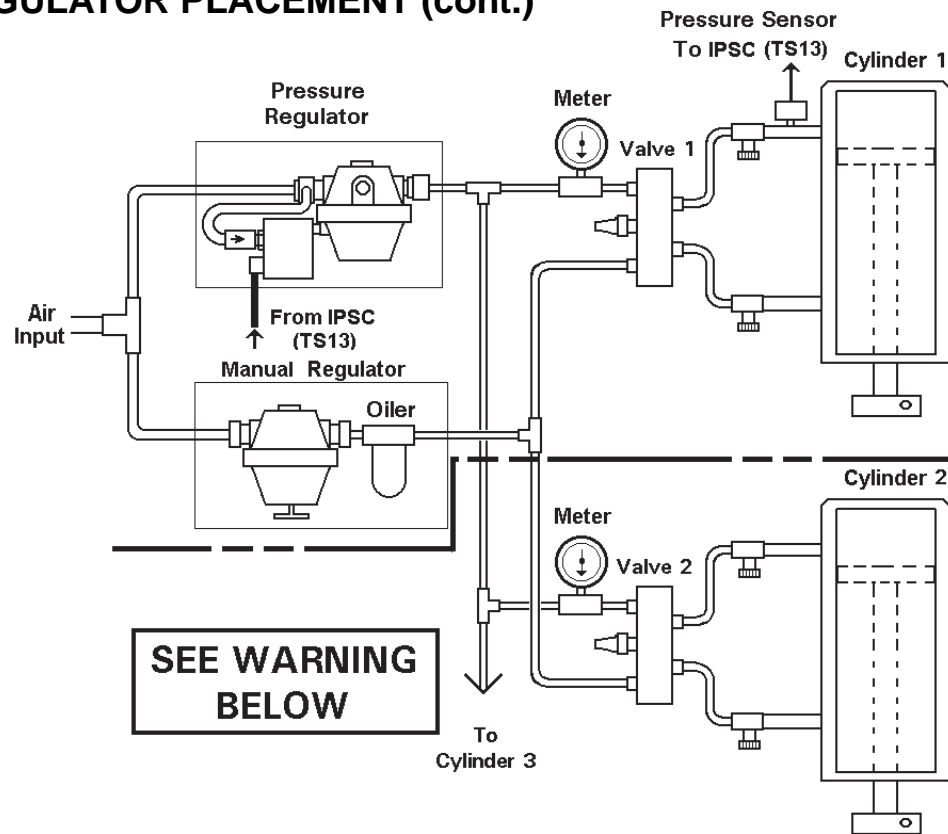

Figure 5-2. IPSC System with Regulator and Sensor in Single function or Cascade control

| ! WARNING ! |
|--|
| Cylinders/Electrodes/Tooling may not stay up/open with Power Off (see Figure 5-2) |
| If Pressure Regulator is used to return the head after the valve is turned off, a disruption in power to the regulator could cause a change in regulated output pressure and gravity may cause the cylinder to return to closed position. Manual regulator should be used as shown in Figure 5-1 and 5-2 to supply return pressure to the cylinder head after the valves 1 and/or 2 are turned off. |

5.2 REGULATOR ELECTRICAL INTERFACE (See Figure 7-5 Logic Diagram)

1. Plug in the interface cable into the Regulator and screw the plug securely in place.
2. Route the interface wiring to the IPSC Board TS13.
3. Connect the cable assembly wire (WHT/BLU) to TS13-1. The shield wire is also connected to this terminal position.
4. Connect the cable assembly wire (ORN/WHT) to TS13-4.
5. Connect the cable assembly wire (BLU/WHT) to TS13-6.
6. Turn on the air supply to the machine.
7. Inspect the fittings for leaks.
8. Turn on power to the control.
9. Program BACKGROUND (RETURN) PRESSURE/FORCE/CURRENT, parameter **b.d.**, and verify pressure settings by using either pressure sensor or pressure gauge.

5.3 OILER PLACEMENT RECOMMENDATIONS

The oiler is recommended to be placed after the booster assembly or placed as shown in Figure 5-1. The oiler may be placed before the Regulator but oil must be kept clean and not allowed to saturate the Regulator.

6.0 PRESSURE SENSOR

The Pressure Sensor (transducer) accurately measures air pressure and converts measurement to an electrical signal. The electrical output is a linear ratio of the sensed pressure. The Sensor is connected to the IPSC or IPS Board through TS13. Signal from the Sensor is converted by the IPSC or IPS Board and sent to the weld Control Board.

The PRESSURE may be displayed by the weld control if the EXTENDED FUNCTION parameter **5.1** is selected. The pressure reading depends on the location of the Sensor.

6.1 SENSOR PLACEMENT

The IPSC pressure sensing element needs to be placed in the system nearest the area where the pressure sensing is desired or is most critical. Since many configurations are possible, actual placement in the system is left to the system designer. The IPSC System option is shown in Figure 5-2 and IPS option in Figure 6-1. As shown in Figure 6-1, Pressure Sensor in a resistance welding application may be placed in at least three different locations.

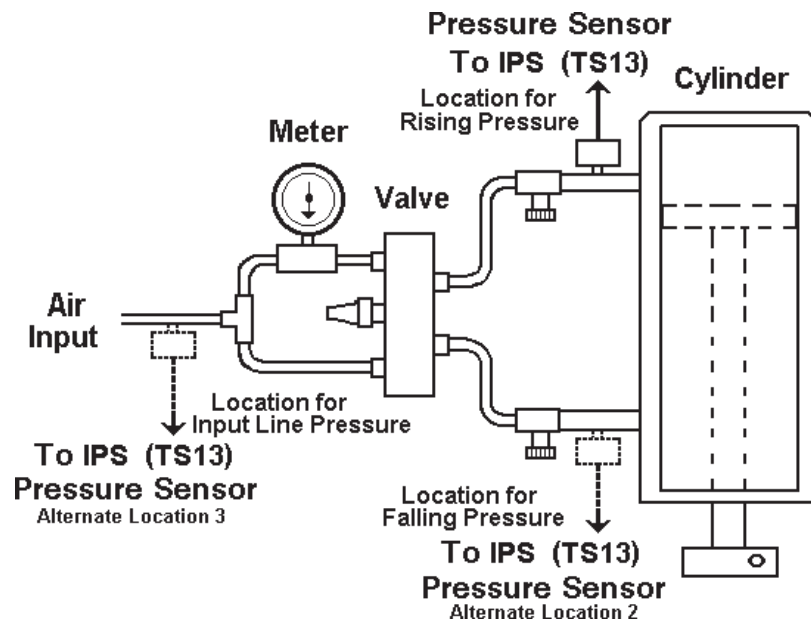

Figure 6-1. IPS System with Sensor

6.1.1 SENSOR PLACEMENT AT TOP OF THE CYLINDER

The top (supply) side of the cylinder is used to trigger for continue the sequence on a rising edge. In this position the Sensor output, displayed in **S.I.**, should match programmed value for REQUIRED PRESSURE **P.r.**, or FORCE **F.r.**, or CURRENT **A.r.**.

6.1.2 SENSOR PLACEMENT AT BOTTOM OF THE CYLINDER

The sensor can be placed on the bottom (exhaust) side of the cylinder, in order to trigger for continue the sequence on a falling edge. In this position the Sensor output, displayed in **S.I.**, should match programmed BACKGROUND (RETURN) value **b.d.** for PRESSURE/FORCE/CURRENT.

6.1.3 SENSOR PLACEMENT ON THE INPUT AIR LINE

The Sensor can be placed on input line in order to trigger for continue the sequence on a rising edge also. In this position the Sensor output, displayed in **S.I.**, should match the programmed value for the REQUIRED PRESSURE **P.r.**, or FORCE **F.r.**, or CURRENT **A.r.**, and the BACKGROUND (RETURN) value **b.d.** also (if applicable).

6.2 DIFFERENTIAL PRESSURE SENSOR

The Integrated Pressure Sense Control System (**IPSC**) was first introduced with single ended Pressure Sensors. These sensors compare the point being measured to atmospheric pressure. As of April 2001, the **IPSC** can be ordered with a Differential Pressure Sensor (Figure 6-2).

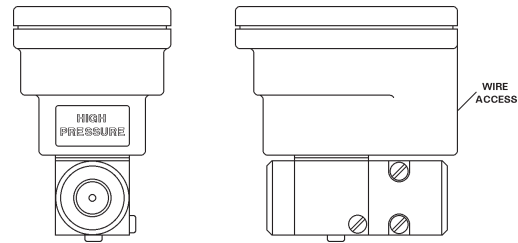

Figure 6-2. Differential Pressure Sensor

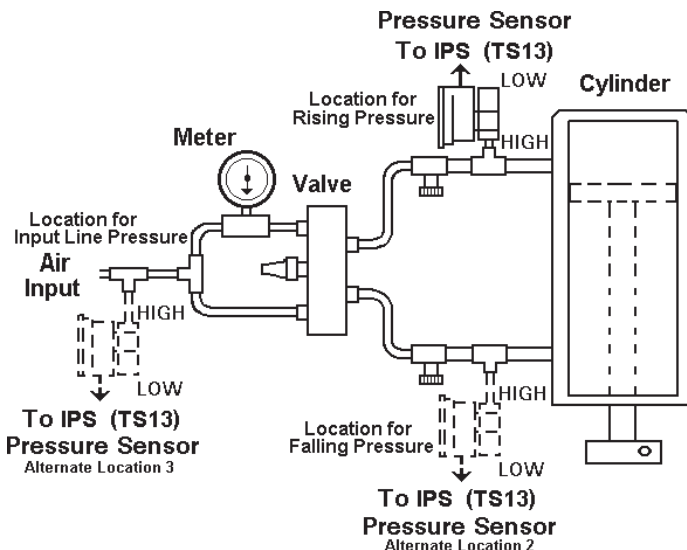

Figure 6-3. IPS System with Differential Pressure Sensor

The Differential Pressure Sensor has two connections, one high and one low. This sensor can be used as a single ended sensor by using only the high pressure port (Figure 6-3).

6.2 DIFFERENTIAL PRESSURE SENSOR (cont.)

Using the Differential Pressure Sensor as shown in Figure 6-4 provides a better indication of actual cylinder force. This Differential Sensor will subtract pressures on the low side of the sensor from the high side. This is useful to detect possible forces in the exhaust side of the cylinder, either intentional (forge operations) or unintentional (restricted exhaust).

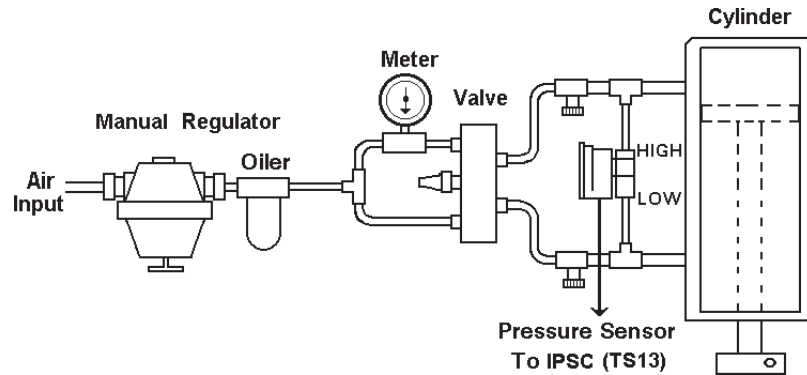

Figure 6-4. *Differential Pressure Sensor location to sense Cylinder position*

6.3 SENSOR ELECTRICAL INTERFACE (See Figure 7-5 Logic Diagram)

1. Connect the Sensor wire (WHT) to TS13-2.
2. Connect the Sensor wire (BLK) to TS13-5.
3. Turn on the air supply and inspect the installation for leaks.

7.0 PRODUCT SPECIFICATIONS

The Regulator and Single Input Sensor with integral cable are made by Proportion-Air. The Differential Pressure Sensor and Single Input Sensor without cable are made by Setra. Similar devices may be substituted.

7.1 PRESSURE REGULATOR WITH VOLUME BOOSTER & FILTER

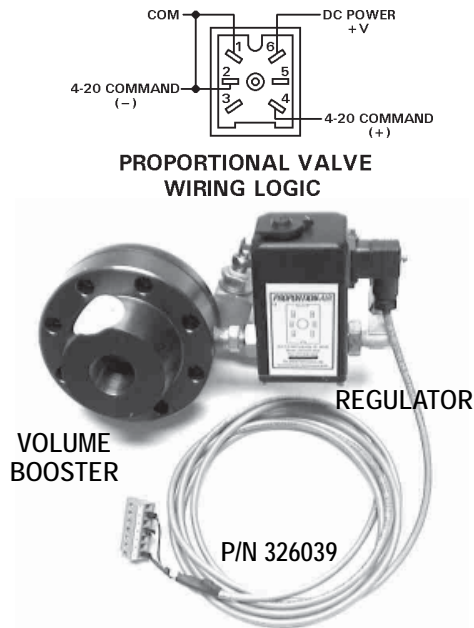

Figure 7-1. *Regulator, Filter, Volume Booster and Cable*

The Regulator with Booster and Filter has P/N 571001 for Internal 1/2" N.P.T., and P/N 571002 for Internal 1 1/4" N.P.T. The Cable Assembly TS13-J13 has P/N 326039.

Operating Temperature: 0°C to 70°C (32°F to 158°F)
 Accuracy: +/- 1% full scale
 Repeatability: 0.1% full scale
 * Operating Pressure: 125 PSI (max.)
 Adjustment Resolution: 0-99 PSI in 1 PSI increments
 Command Current: 4-20 mA at 100 ohms impedance
 Port Size: Internal 1/2" N.P.T. or 1 1/4" N.P.T.
 Filtration: 20 micron nominal
 Response Time: 40-50 mS (typical)
 Construction: Aluminum, Zinc, Acetal, Brass, Buna-n
 Proportional Valve Type: Diaphragm
 Flow Rate (High): 100 scfm at 80 PSI for 1/2"
 250 scfm at 80 PSI for 1 1/4"

7.2 SINGLE INPUT PRESSURE SENSORS

7.2.1 PRESSURE SENSOR Available after 8/02

The Sensor without cable has P/N 571005. Sensor supplied with cable P/N 326053 has P/N 600633.

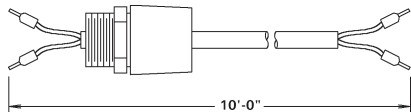

Operating Temperature: -40°C to 127°C (-40°F to 260°F)
 Accuracy: +/- .25% full scale
 Repeatability: 0.05% full scale
 Adjustment Resolution: 0-99 PSI in 1 PSI increments
 Output Current: 4-20 mA
 Operating Pressure: 200 PSI maximum
 Input Size: External 1/4" N.P.T.
 Construction: Stainless Steel, Valox, 17-4 PH S.S.
 Response Time: 5 mS (DC output)
 Sensing Device Construction: Variable Capacitance

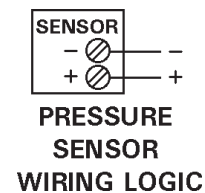

Figure 7-2. *Pressure Sensor without integral cable*

* Operating Pressure shown is for QB1 electronic Regulator. Volume Booster can be operated alone with 400 PSI (max.). Contact factory for more information.

7.2.2 PRESSURE SENSOR Available since 11/97

The Sensor with cable has P/N 600633.

Operating Temperature: 0°C to 70°C (32°F to 158°F)
Accuracy: +/- 1% full scale
Repeatability: 0.1% full scale
Adjustment Resolution: 0-99 PSI in 1 PSI increments
Output Current: 4-20 mA
Operating Pressure: 250 PSI maximum
Input Size: External 1/4" N.P.T.
Construction: Aluminum, Brass, Viton
Response Time: 100 mS (DC output)
Sensing Device Construction: solid state, silicon etched device

NOTICE

Depending on availability, either Sensor with cable or Sensor without cable may be supplied.

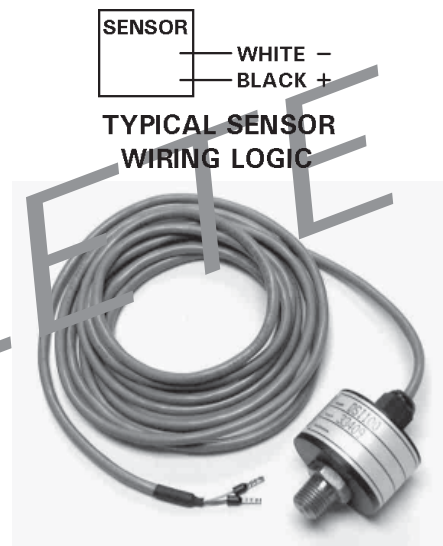
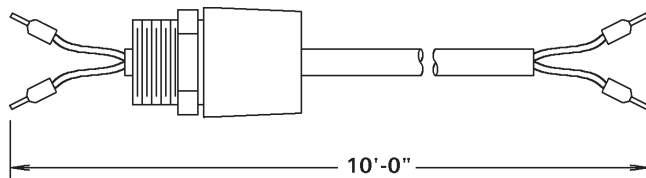

Figure 7-3. Sensor with cable

7.3 DIFFERENTIAL PRESSURE SENSOR

The Differential Pressure Sensor is P/N 571004.
Supplied with cable P/N 326053.



Operating Temperature: -22°C to 80°C (0°F to 175°F)
Accuracy: +/- 1% full scale
Non-Repeatability: 0.05% full scale
Output Current: 4-20 mA
Operating Pressure: 250 PSI maximum
Input Size: Internal 1/4" N.P.T.
Construction: Aluminum, Stainless Steel, Viton
Response Time: 30-50 mS (DC output)

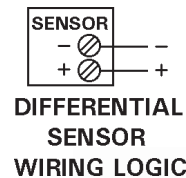

Figure 7-4. Differential Sensor

7.4 CUSTOMER PROVIDED HARDWARE WIRING

When customer provides Pressure Regulator and/or Pressure Sensor, use information in Figure 7-5 to wire to IPSC Option PCB 410354-Series with Standard Sensor and Regulator.

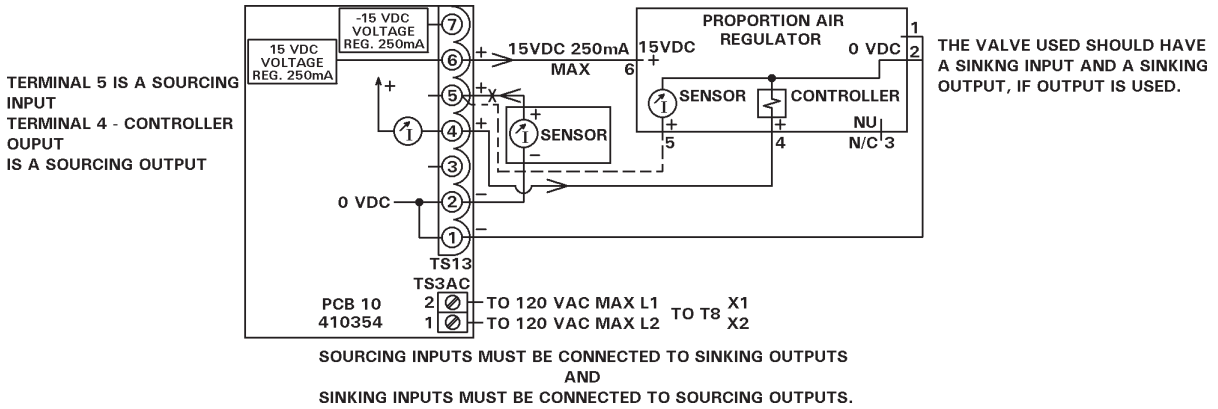

Figure 7-5. IPSC Wiring Logic – Proportion-Air

When customer provides Pressure Regulator and/or Pressure Sensor, use information in Figure 7-6 to wire to IPSC Option PCB 410354 with SMC or other customer provided Controller Regulator.

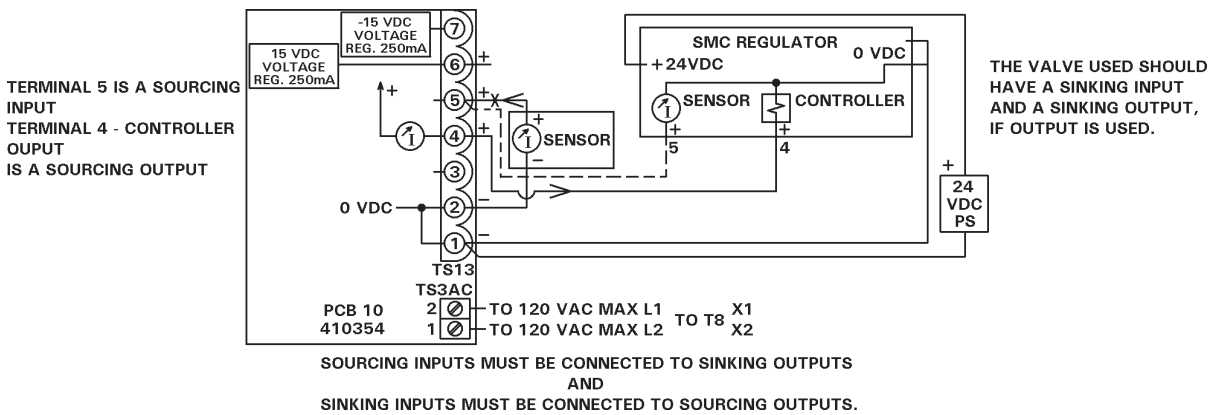

Figure 7-6. IPSC Wiring Logic – SMC or other customer provided Controller

When customer provides a Sourcing Sensor, use information in Figure 7-7 to wire to IPS Option PCB 410354-003 or IPSC Option PCB 410354-004, removing Jumper J1 (see also Figure 7-8).

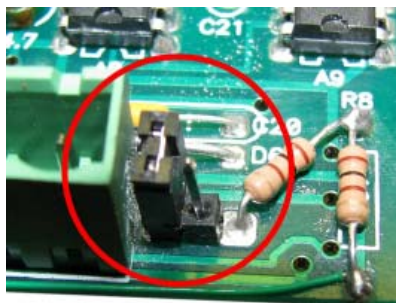

Figure 7-8. Sourcing Sensor Jumper detail

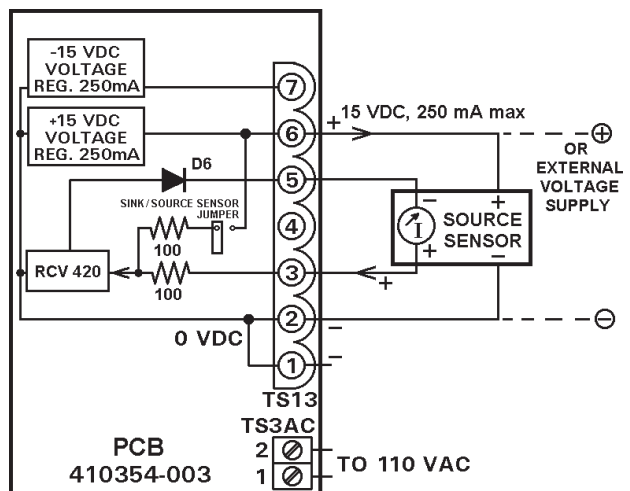

Figure 7-7. 410354-003 Sourcing Sensor Wiring Logic

7.4 CUSTOMER PROVIDED HARDWARE WIRING (cont.)

When customer provides a Sinking Sensor, use information in Figure 7-9 to wire to IPS Option PCB 410354-003 or IPSC Option PCB 410354-004, installing Jumper J1 (see also Figure 7-10).



Figure 7-10. Sinking Sensor Jumper detail

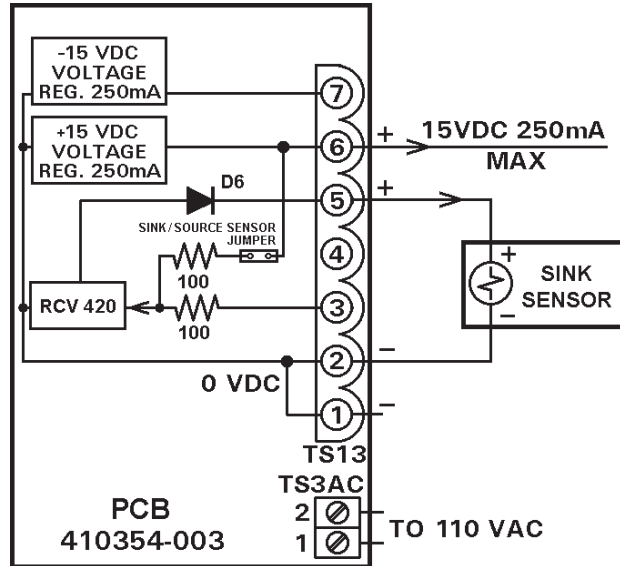

Figure 7-9. 410354-003 Sinking Sensor Wiring Logic

7.5 SINKING/SOURCING BLOCK DIAGRAM

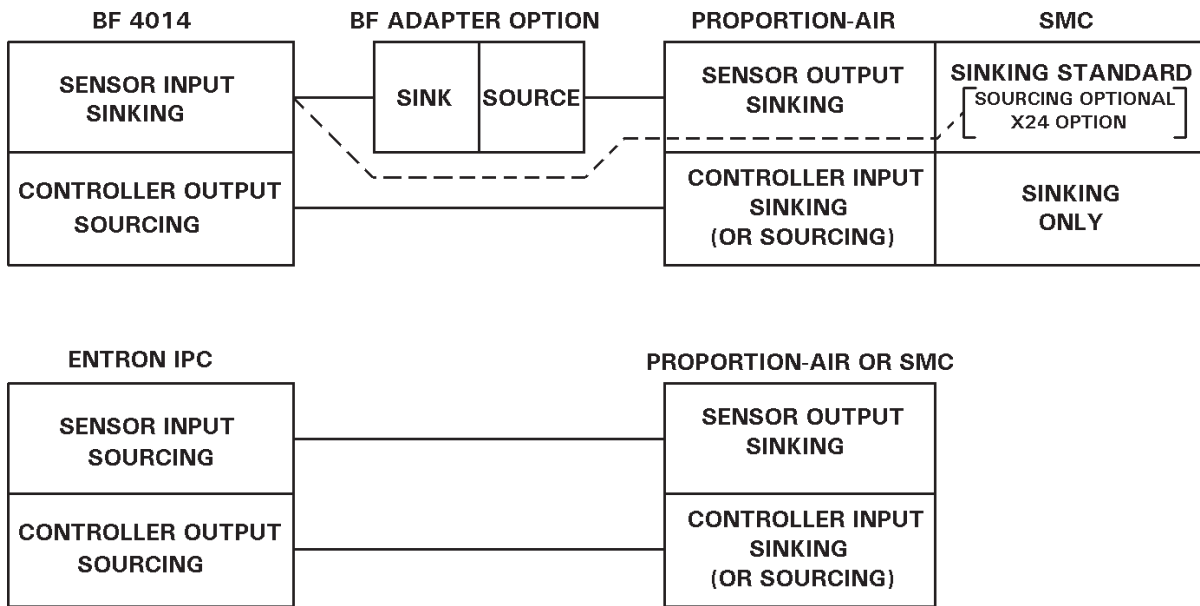

Figure 7-11. Sinking/Sourcing Block Diagram

8.0 TROUBLESHOOTING

Refer to Manual and Wiring Diagrams for location of fuses, terminal strips, etc. Refer to Wiring and Logic Diagrams for Bills of Material.

| TROUBLE | POSSIBLE CAUSE | SOLUTION |
|--|---|--|
| Control will not change pressure. | <ol style="list-style-type: none"> 1. Programming error. 2. Bad fuse F18 (1/4 A). 3. Clogged filter. | <ol style="list-style-type: none"> 1. Follow programming instructions. 2. Replace fuse. 3. Clean filter. |
| ERROR 36 (IPSC or IPS Option). | <ol style="list-style-type: none"> 1. Not reaching actual preset point. 2. Pressure Sensor connected incorrectly. 3. No power on the IPSC Board. | <ol style="list-style-type: none"> 1. Check parameters in control. Check line pressure. 2. Review wiring or check for open circuit. 3. Check fuse F18 and power 110 VAC on TS3AC. |
| Sensor input 5.I. display always maximum value. | <ol style="list-style-type: none"> 1. Pressure Sensor connected incorrectly. 2. No power on the IPSC Board. | <ol style="list-style-type: none"> 1. Review wiring or check for open circuit. 2. Check fuse F18 and power 110 VAC on TS3AC. |
| Cylinder falls at the end of sequence or stays down (Pressure Control Option). | <ol style="list-style-type: none"> 1. No Background (Return) Pressure Setting b.d.. 2. Background (Return) pressure not high enough to lift the cylinder. 3. May need manual regulator. | <ol style="list-style-type: none"> 1. Program b.d. value in the control. 2. Change b.d. value. 3. Install manual regulator. |
| Valve will not shuttle. | <ol style="list-style-type: none"> 1. Pressure too low to operate valve. 2. Solenoid valve not programmed in schedule. | <ol style="list-style-type: none"> 1. Increase pressure or change to pilot assist type valve. 2. Program a valve in the schedule. |
| Welding control initiates and valve light comes on, but electrodes do not close. | <ol style="list-style-type: none"> 1. Solenoid valve mis-wired. 2. Bad fuse F6, F7 or F8 (1 A). 3. Clogged filter. | <ol style="list-style-type: none"> 1. Check all solenoid terminals for proper wiring or open connections. 2. Replace fuse. 3. Clean filter. |

8.1 INTEGRATED PRESSURE SENSE & CONTROL BLOCK DIAGRAM

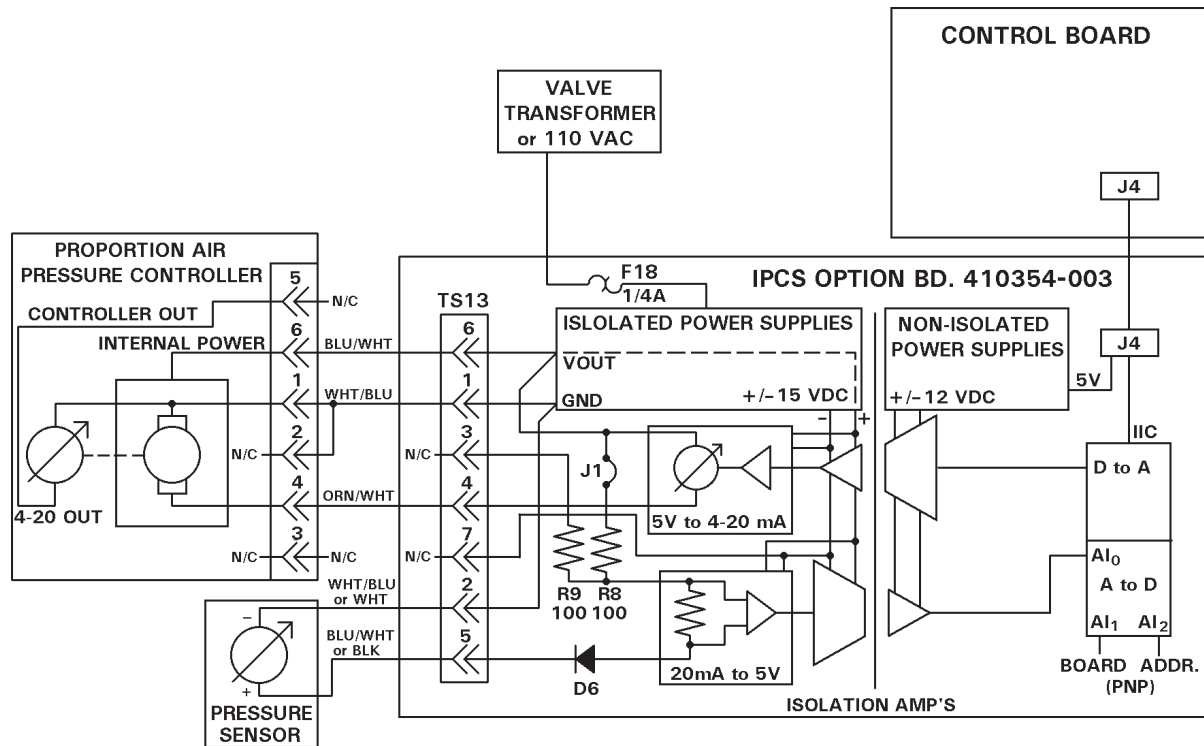

Figure 8-1. *IPSC block diagram*

The block diagram above may be useful in understanding Pressure Sense and Control operation and aid in troubleshooting.

When troubleshooting the Pressure Control operation:

1. A volt meter can be used to confirm 120 VAC input to the IPCS Option Board 410354.
2. A DC volt meter can check for VOUT (approx. 15 VDC) between TS13-1 and TS13-6.
3. The weld control WHT can be used to vary pressure output and an Amp meter can be placed in series with the TS13-4 connection to check for current variations from 4 mA (0 PSI) to 20 mA (99 PSI).

When troubleshooting the Pressure Sense operation:

1. A volt meter can be used to confirm 120 VAC input to the IPCS Option Board 410354.
2. A DC volt meter can check for VOUT (approx. 15 VDC) between TS13-1 and TS13-6.
3. The source of pressure that is being monitored can be varied and an Amp meter be placed in series with the sensor (TS13-2 or -5) and the reading should change from 4 mA (0 PSI) to 20 mA (99 PSI).

9.0 IPSC RETROFIT KIT BILL OF MATERIAL

| EN1000 CONTROLS ALL CABINET STYLES | | | | | | | | | EN1001 CONTROLS ALL CABINET STYLES | | | | | | | | | PART NO. | DESCRIPTION |
|---------------------------------------|------------|------------|------------|------------|------------|------------|------------|------------|---------------------------------------|------------|------------|------------|------------|------------|------------|------------|------------|------------|---|
| IP | IPS | IPSD | IPC2 | IPC5 | IPSC2 | IPSC5 | IPSCD2 | IPSCD5 | IP | IPS | IPSD | IPC2 | IPC5 | IPSC2 | IPSC5 | IPSCD2 | IPSCD5 | | |
| 600699-001 | 600699-002 | 600699-003 | 600699-004 | 600699-005 | 600699-006 | 600699-007 | 600699-008 | 600699-009 | 600700-001 | 600700-002 | 600700-003 | 600700-004 | 600700-005 | 600700-006 | 600700-007 | 600700-008 | 600700-009 | | |
| + | + | + | + | + | + | + | + | + | | | | | | | | | | 600541 | ASSEM SEQ. CTRL/DISPLAY BD. EN1000 |
| | | | | | | | | | x | x | x | x | x | x | x | x | x | 600572-002 | ASSEM SEQ. CTRL/DISPLAY BD. EN1001 |
| 1 | | | | | 1 | 1 | 1 | 1 | 1 | | | | | 1 | 1 | 1 | 1 | 410354 | ASSEM, IPSC PCB* |
| | 1 | 1 | | | | | | | | 1 | 1 | | | | | | | 410354-002 | ASSEM, IPS PCB* |
| | | | 1 | 1 | | | | | | | | 1 | 1 | | | | | 410354-001 | ASSEM, IPC PCB |
| | 1 | | | | 1 | 1 | | | | 1 | | | | 1 | 1 | | | 600633 | ASSEM, PRESSURE SENSE |
| | | 1 | | | | | 1 | 1 | | | 1 | | | | | 1 | 1 | 571004 | DIFFERENTIAL PRESSURE SENSE |
| | | 1 | | | 1 | 1 | 1 | 1 | | | 1 | | | 1 | 1 | 1 | 1 | 326053 | ASSEM, CABLE DIFFERENTIAL PRESSURE SENSE |
| | | | 1 | | 1 | | 1 | | | | | 1 | | 1 | | 1 | | 571001 | PROPORTIONAL VALVE, ½ NPT |
| | | | 1 | | 1 | | 1 | | | | | 1 | | 1 | | 1 | | 326039 | CABLE ASSEM, PCS CTRL TO PROPORTIONAL VALVE |
| | | | | 1 | | 1 | | 1 | | | | | 1 | | 1 | | 1 | 571002 | PROPORTIONAL VALVE, 1-1/4 NPT |
| 1 | 1 | 1 | 1 | 1 | 1 | 1 | 1 | 1 | 1 | 1 | 1 | 1 | 1 | 1 | 1 | 1 | 1 | 322466 | ASSEM, HARNESS J4-J4, 36" LG. |
| 1 | 1 | 1 | 1 | 1 | 1 | 1 | 1 | 1 | 1 | 1 | 1 | 1 | 1 | 1 | 1 | 1 | 1 | 322467 | ASSEM, HARNESS, TS3AC-T3, 32" LG. |
| 2 | 2 | 2 | 2 | 2 | 2 | 2 | 2 | 2 | 2 | 2 | 2 | 2 | 2 | 2 | 2 | 2 | 2 | 555010 | STANDOFF, 6-32 X 3/4 |
| 4 | 4 | 4 | 4 | 4 | 4 | 4 | 4 | 4 | 4 | 4 | 4 | 4 | 4 | 4 | 4 | 4 | 4 | 557006 | 6-32 X 3/8 PHSMS, PHIL, BRITE |
| 2 | 2 | 2 | 2 | 2 | 2 | 2 | 2 | 2 | 2 | 2 | 2 | 2 | 2 | 2 | 2 | 2 | 2 | 557017 | #6 SPLIT L/W |
| 2 | 2 | 2 | 2 | 2 | 2 | 2 | 2 | 2 | 2 | 2 | 2 | 2 | 2 | 2 | 2 | 2 | 2 | 342008 | CABLE CLIP, "U", ADHESIVE BACK |
| 2 | 2 | 2 | 2 | 2 | 2 | 2 | 2 | 2 | 2 | 2 | 2 | 2 | 2 | 2 | 2 | 2 | 2 | 342012 | CABLE CLAMP, FLAT, ADHESIVE BACK |
| 1 | 1 | 1 | 1 | 1 | 1 | 1 | 1 | 1 | 1 | 1 | 1 | 1 | 1 | 1 | 1 | 1 | 1 | 421417 | WIRING DIAGRAM, OPTIONAL INTEGRATED PRESSURE CONTROL SYSTEM |

- + For customers with EN1000 Sequence Control/Display Board 600541 Revision **WW** with PROM firmware version 619016-002G or later, a new Sequence Control/Display Board will not be required. If Control Board does not meet this requirement, the Control Board must be updated or a new Board purchased.
- x For customers with EN1001 Sequence Control/Display Board 600572-002 Revision **T** with PROM firmware version 619016-001N or later, a new Sequence Control/Display Board will not be required. If Control Board does not meet this requirement, the Control Board must be updated or a new Board purchased.
- * For customers using Sourcing or Sinking Sensor, see Figures 7-7, 7-8, 7-9, and 7-10 (in Section 7.4) and Figure 7-11 (in Section 7.5) for more details.

9.0 IPSC RETROFIT KIT BILL OF MATERIAL (cont.)

| EN1000 CASCADE ALL CABINET STYLES | | | | | | | | | EN1001 CASCADE ALL CABINET STYLES | | | | | | | | | PART NO. | DESCRIPTION |
|--------------------------------------|------------|------------|------------|------------|------------|------------|------------|------------|--------------------------------------|------------|------------|------------|------------|------------|------------|------------|------------|------------|---|
| IP | IPS | IPSD | IPC2 | IPC5 | IPSC2 | IPSC5 | IPSCD2 | IPSCD5 | IP | IPS | IPSD | IPC2 | IPC5 | IPSC2 | IPSC5 | IPSCD2 | IPSCD5 | | |
| 600719-001 | 600719-002 | 600719-003 | 600719-004 | 600719-005 | 600719-006 | 600719-007 | 600719-008 | 600719-009 | 600720-001 | 600720-002 | 600720-003 | 600720-004 | 600720-005 | 600720-006 | 600720-007 | 600720-008 | 600720-009 | | |
| + | + | + | + | + | + | + | + | + | | | | | | | | | | 410321 | ASSEM, PROG. BD. EN1000 CASCADE |
| | | | | | | | | | x | x | x | x | x | x | x | x | x | 410363 | ASSEM, PROG. BD. EN1001 CASCADE |
| 1 | | | | | 1 | 1 | 1 | 1 | 1 | | | | | 1 | 1 | 1 | 1 | 410354 | ASSEM, IPSC PCB* |
| | 1 | 1 | | | | | | | | 1 | 1 | | | | | | | 410354-002 | ASSEM, IPS PCB* |
| | | | 1 | 1 | | | | | | | 1 | 1 | | | | | | 410354-001 | ASSEM, IPC PCB |
| | 1 | | | | 1 | 1 | | | | 1 | | | | 1 | 1 | | | 600633 | ASSEM, PRES. SENSE |
| | | 1 | | | | | 1 | 1 | | | 1 | | | | | 1 | 1 | 571004 | DIFFERENTIAL PRES. SENSE |
| | | 1 | | | | | 1 | 1 | | | 1 | | | | | 1 | 1 | 326053 | ASSEM, CABLE DIFFERENTIAL PRES. SENSE |
| | | | 1 | | 1 | | 1 | | | | | 1 | | 1 | | 1 | | 571001 | PROP. VALVE, ½ NPT |
| | | | | 1 | | 1 | | 1 | | | | | 1 | | 1 | | 1 | 571002 | PROP. VALVE, 1-1/4 NPT |
| 1 | 1 | 1 | 1 | 1 | 1 | 1 | 1 | 1 | 1 | 1 | 1 | 1 | 1 | 1 | 1 | 1 | 1 | 322485 | ASSEM, HARNESS J4B-J4, 33" LG. |
| 1 | 1 | 1 | 1 | 1 | 1 | 1 | 1 | 1 | 1 | 1 | 1 | 1 | 1 | 1 | 1 | 1 | 1 | 322486 | ASSEM, HARNESS, TS3AC-T3, 50" LG. |
| 2 | 2 | 2 | 2 | 2 | 2 | 2 | 2 | 2 | 2 | 2 | 2 | 2 | 2 | 2 | 2 | 2 | 2 | 555010 | STANDOFF, 6-32 X 3/4 |
| 4 | 4 | 4 | 4 | 4 | 4 | 4 | 4 | 4 | 4 | 4 | 4 | 4 | 4 | 4 | 4 | 4 | 4 | 557006 | 6-32 X 3/8 PHSMS, PHIL, BRITE |
| 2 | 2 | 2 | 2 | 2 | 2 | 2 | 2 | 2 | 2 | 2 | 2 | 2 | 2 | 2 | 2 | 2 | 2 | 557017 | #6 SPLIT LW |
| 2 | 2 | 2 | 2 | 2 | 2 | 2 | 2 | 2 | 2 | 2 | 2 | 2 | 2 | 2 | 2 | 2 | 2 | 342008 | CABLE CLIP, "U", ADHESIVE BACK |
| 2 | 2 | 2 | 2 | 2 | 2 | 2 | 2 | 2 | 2 | 2 | 2 | 2 | 2 | 2 | 2 | 2 | 2 | 342012 | CABLE CLAMP, FLAT, ADHESIVE BACK |
| 1 | 1 | 1 | 1 | 1 | 1 | 1 | 1 | 1 | 1 | 1 | 1 | 1 | 1 | 1 | 1 | 1 | 1 | 421417-001 | WIRING DIAGRAM, OPTIONAL INTEGRATED PRESSURE CONTROL SYSTEM, CASCADE CONTROLS |

+ For customers with EN1000 Cascade Program Board 410321 Revision **CC** with PROM firmware version 619044-002A or later, a new Program Board will not be required. If Control Board does not meet this requirement, the Control Board must be updated or a new Board purchased.

x For customers with EN1001 Cascade Program Board 410363 Revision **H** with PROM firmware version 619044-002 **Original** or later, a new Program Board will not be required. If Control Board does not meet this requirement, the Control Board must be updated or a new Board purchased.

* For customers using Sourcing or Sinking Sensor, see Figures 7-7, 7-8, 7-9 and 7-10 (in Section 7.4) and Figure 7-11 (in Section 7.5) for more details.

9.1 FIELD INSTALLATION OF RETROFIT IPSC OPTION

1. Remove **ALL** power to control and open door.
2. In EN1000 and EN1001 Controls, if the revision letter on the Control Board is earlier than the new Control Board included with this kit, remove and replace the old Control Board with the new Board.
3. In “B”, “S”, and “E” Cabinets, mount Integrated Pressure Option Board on the existing standoffs indicated in Figure 9-1, using the 6-32 screws included with the kit.
4. In “T/D” and NEMA 12 Enclosures, modify the cabinet in **ONLY** the mounting position to be used with clearance holes for 6-32 fasteners and mount the Integrated Pressure Option Board using the 6-32 screws, lockwashers, and standoffs included with the kit.
5. After the Option Board is mounted, complete the installation of included Harness Assemblies J4-J4 and TS3AC-T3 as well as a Proportional Valve and/or Pressure Sensor using Wiring Diagram 421417 included with the kit.

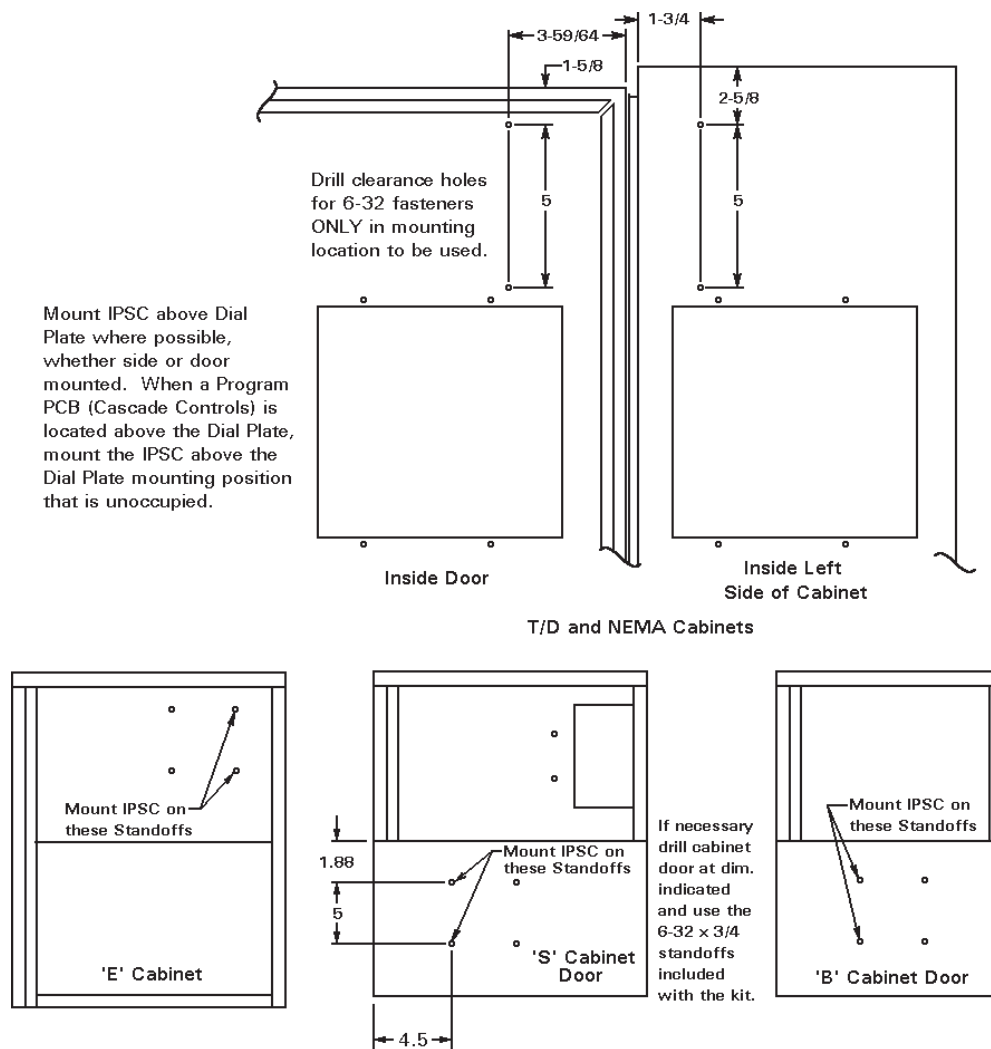

Figure 9-1. IPSC mounting diagrams

10.0 ENTRON LIMITED WARRANTY AND FACTORY SERVICE

ENTRON Controls, LLC., warrants that all ENTRON control panels, **EXCEPT** the silicon controlled rectifiers (SCRs), SCR and IGBT assemblies, circuit breakers, and electro-mechanical contactors, are free of defects for a period of **TWO YEARS** from the date of original purchase and, in the event of a manufacturing defect, ENTRON will repair or replace, at its discretion, the defective part without any cost for parts or labor.

All silicon controlled rectifiers, SCR and IGBT assemblies, and circuit breakers in ENTRON control panels are covered by a limited warranty from the original manufacturer (other than ENTRON). If these parts fail because of a manufacturing defect, they will not be repaired or replaced by ENTRON, but will be returned by ENTRON to the original manufacturer in accordance with said manufacturer's warranty.

To obtain repairs or replacement parts under this warranty, the defective parts must be returned, prepaid, to ENTRON Controls, LLC., 601 High Tech Court, Greer, SC 29650. Please send your repair to the attention of "service" with a description of the problem you are experiencing, contact person and phone number.

EXCLUSIONS: This warranty does not cover damage by accident, misuse, unauthorized repair or modification to any control assembly by the customer.

IMPORTANT NOTE: The warranty period is considered from the date of shipment and is tracked by a serial number code.

USE OF "OUT OF WARRANTY" REPAIR SERVICE:

To obtain service for any printed circuit board assembly after two years from the date of purchase, send the assembly, prepaid, to ENTRON Controls, LLC., and ENTRON will repair the printed circuit board assembly and return it to you without further warranty on its part. Additional service charges will be invoiced at time of shipment.

Your ENTRON Controls, LLC., representative is always available to assist you with your control or welding problems. Our sales representatives, Original Equipment Manufacturers, Dealers and Distributors are always supported by direct factory assistance. Do not hesitate to call for prompt, professional assistance — 864-416-0190. There is no charge for this assistance.

APPENDIX A

ORDERING INFORMATION

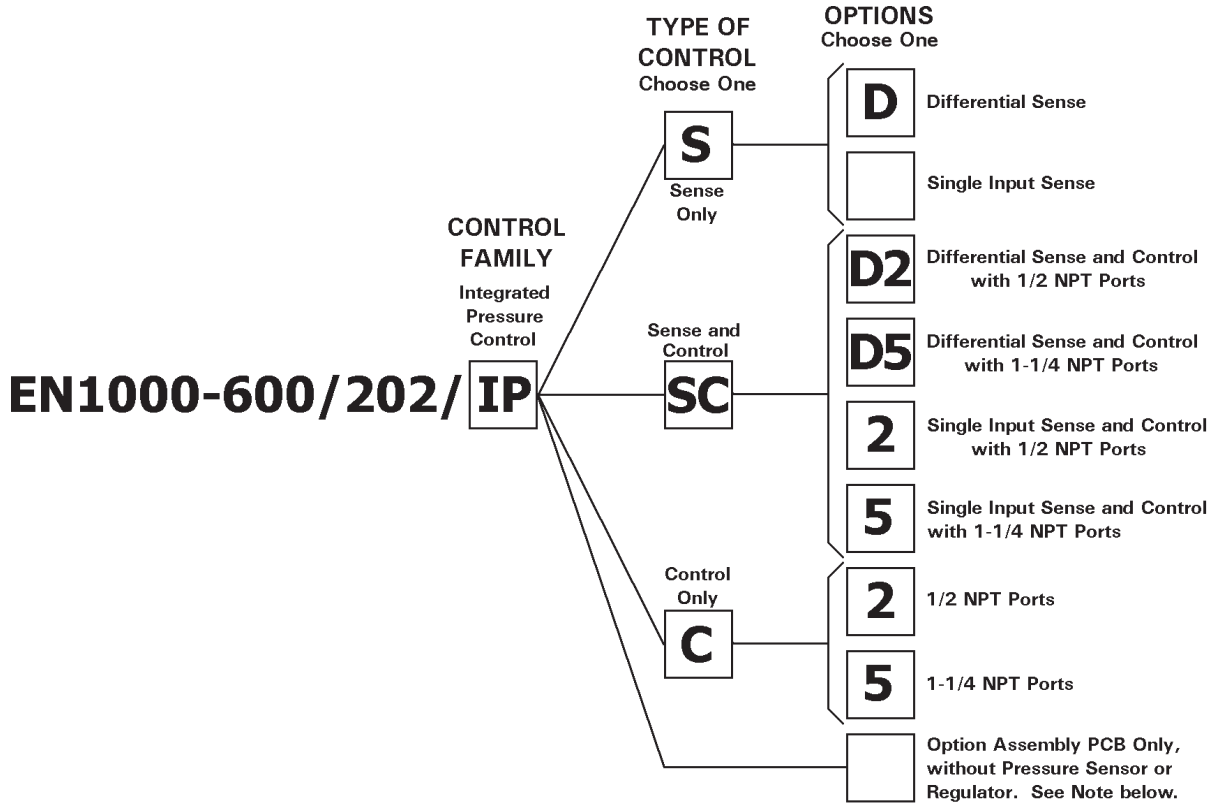

EXAMPLES:

- EN1000-600D/202/IP SC 2** An EN1000-600D Control with a 200Amp 2 Pole Circuit Breaker and an Integrated Pressure Control Option with Single Input Pressure Sense and Control with 1/2 NPT Ports.
- EN1000-600D/202/IP S** An EN1000-600D Control with a 200Amp 2 Pole Circuit Breaker and an Integrated Pressure Control Option with Single Input Pressure Sense.
- EN1000-600D/202/IP** An EN1000-600D Control with a 200Amp 2 Pole Circuit Breaker and an Integrated Pressure Control Option without Pressure Sensor or Pressure Regulator.

NOTE: Units will ship with PCB Assembly No. 410354, 410354-001, or 410354-002 for Sinking Sensors. PCB A/N 410354-003 and 410354-004 are available for use in Source Sensing applications, see Section 2.0.