

INTERTRON INDUSTRIES, INC.

MODEL 302A CONTROLLER

REFERENCE MANUAL

REV. C May 21, 1999

www.intertron-ind.com

INTERTRON INDUSTRIES INCORPORATED WARRANTY

The Model 302A Welding Controller has a limited warranty of one year parts and labor, FOB, Santa Ana, California, from the date of purchase. During that period, upon prepaid return to the distributor or the factory, equipment proving to be defective will be repaired (or at our option, replaced) without charge for either material or labor. No responsibility will be assumed for damage to equipment through improper installation, or through attempts to operate it above its rated capacity, intentional or otherwise.

The SCR's used in the ignitron firing module or SCR contactors are warranted for 90 days, if correct installation procedures are used, and the welding machine has load resistors on all primary windings and a tip arc relay.

***WARRANTY EXTENSION, as of May 01, 2001 the limited warranty of one year parts and labor has been extended to THREE years. Any items purchased prior to May 01, 2001 retains the limited warranty of one year parts and labor. In addition, the warranty for the SCR's used in the ignitron firing module or SCR contactors has been extended from 90 days to ONE year, if correct installation procedures are used.**

In addition, the warranty does not cover any customer equipment to which the Model 302A is installed.

TABLE OF CONTENTS

INTERTRON INDUSTRIES INCORPORATED WARRANTY	1
INTRODUCTION	2
INSTALLATION	3
INTERLOCK SCANNER INTERCONNECTION	6
WELD SEQUENCE START-UP TEST	6
REMOTE CONTROL BOX FUNCTIONS AND OPERATION	7
POSITIVE, NEGATIVE AND ALTERNATE POLARITY SWITCH	9
SPOT - SEAM - ROLL SWITCH	9
WELD SCHEDULE SETTING	9
PROGRAMMABLE TIMING OF EVENTS OF A PREARRANGED SEQUENCE IN A WELD SCHEDULE	10
FORGE PROGRAM	11
SPOT - SEAM - ROLLSPOT OPERATION	11
PHASE REVERSAL DURING IMPULSE OPERATION	12
PROGRAM SETTING	12
MAINTENANCE AND PERIPHERAL DIAGNOSTICS	13
RESET ON POWER FAILURE	13
3 PHASE LINE VOLTAGE COMPENSATION MODEL 302L	14
INSTALLATION PROCEDURE	14
CALIBRATION PROCEDURE	14
VISUAL TROUBLESHOOTING DISPLAY	16
OPERATING MODE SETTING	17
SET MAXIMUM ALLOWABLE NUMBER OF: 1. IMPULSES; 2. HEAT CYCLES; 3. HEAT DECAY CYCLES	18
SCHEMATICS	19

INTRODUCTION

Intertron Industries Incorporated Resistance Welding Controller Model 302A is a well proven microprocessor technology. Its design and construction is the sum total of twenty-six years of experience in welding controller design. The sophistication of today's electronics is used to simplify the welders operating procedures and logistics of operations. The microcomputer powers are used to greatly enhance the flexibility of programming and storing programs.

In the following pages we will attempt to give the user a working knowledge of the control system and its parameters.

CAUTION: Read carefully the installation instructions, prior to installation.

INSTALLATION

The Resistance Welding Controller Model 302A is designed to interface with Sciaky Spot Weld/Seam Weld frequency converter type welding machines; however, it is not limited to these types only and can also be used with 3 phase rectified D.C. welding machines.

An installation wiring diagram DRW. NO. 1030-092-02 is supplied with each manual.

It is recommended that this drawing be studied carefully prior to installation.

The installation diagram below shows the minimum required basic package.

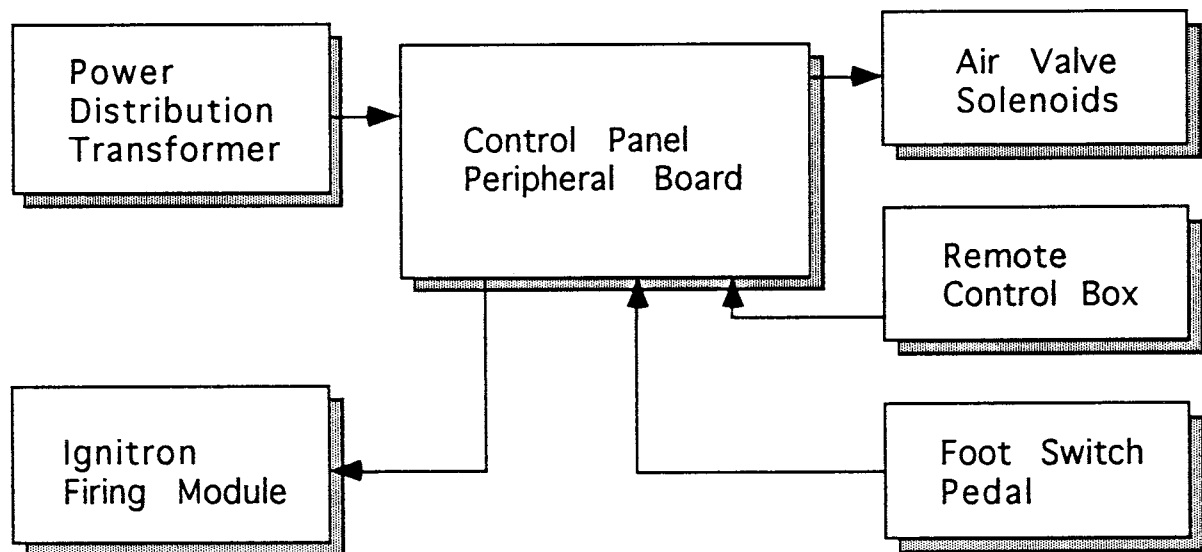

The ignitron firing module package recommended is the model 402B. They should be located in the proximity of the ignitrons whenever possible.

It is recommended on a new installation, where an old controller has been removed and its ignitrons were fired by thyratrons, that the ignitrons be replaced with new ones. If an old ignitron is hard and slow firing it will damage the SCR'S in the ignitron firing module.

Use 20 OHM Power Resisters built for this application across each primary.

For a TIP ARC RELAY it is recommended to use the square "D" type HO-40 Series D Class 8501, with 110V AC coil. This relay has 4 reversible poles with a current carrying capacity of 20 Amps per pole. Prior to installation reverse the poles to normally closed and connect them in parallel as shown in the diagram below.

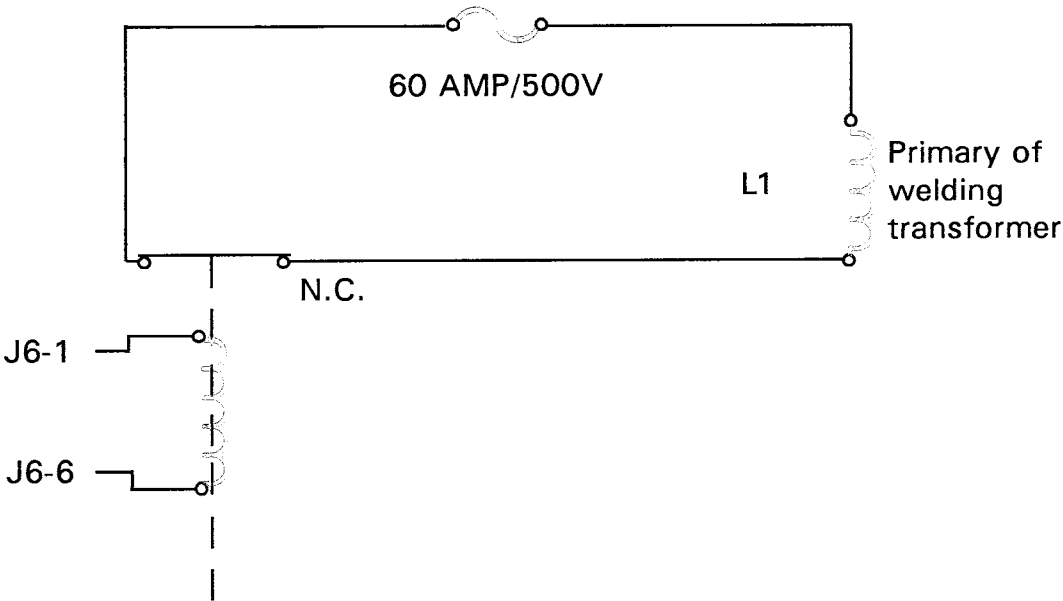

Install the power distribution transformer and modules 402B wherever convenient within the welding machine. The transformer input accepts A/C power from 200VAC to 500VAC 60 HZ. Fuse inputs with two 1 AMP 600V fuses. Prior to installation connect phase A transformer to proper voltage tap. Failure to do so will result in damage or improper or marginal operation of the system. Measure the line voltage between L1 and L2 with an A/C voltmeter and connect tap to the closest appropriate place. It is important to observe correct phase wiring as shown in the wiring diagram. Failure to do so could result in cross firing and possible damage to contactors or ignitron firing modules.

The system interconnect diagram illustrates the interconnection to the retraction, weld, forge, key, water valves and TIP ARC relay. Motor/clutch relay is driven by the same output that energizes the KEY IN valve solenoid. Observe that the jumper on the peripheral board TB2 is in the proper place (See DRW. 1050-102-01). All solenoid coils must be 110VAC 20-30VA. For retraction systems not using a KEY IN solenoid ignore connections to M.S. (h.d.) and M.S. (key in). The system interconnect diagram shows the following air valves:

Retraction	Valve	N.O.	Solenoid	Coil	110VAC
Weld	Valve	N.C.	Solenoid	Coil	110VAC
Forge	Valve	N.O.	Solenoid	Coil	110VAC
Key	Valve	N.C.	Solenoid	Coil	110VAC
Motor		SPDT	Relay	Coil	110VAC

The foot switch used is a 3 stage foot switch with 3 microswitches which are sequentially closed by foot depression on the switch. The first microswitch (F.S.A.) is mechanically locked in the "ON" position and controls the retraction valve.

The second microswitch (F.S.I.) energizes the weld valve and is called first stage initiation. By removing foot depression from first stage, weld valve will de-energize and control will return to "OFF" state (stand by mode).

The third microswitch in the foot switch is called FS2. This starts the counting sequence. Once depressed the sequence event cannot be aborted until return to stand by mode. The only way to abort sequence is to turn off emergency halt switch (TB1-2; TB1-3) on peripheral board.

All solid state relays operating valves and other A/C relays are getting their on/off signals from the processor board. A LED module "LM1" with adjacent legends enable the maintenance personnel to view the sequence of events in valve operation statically and dynamically.

A lit L.E.D. indicates the appropriate relay is energized. Two L.E.D.'s are monitoring contact closure of M.S. head down and M.S. key in.

Three L.E.D.'s are monitoring contact closure of F.S.A.; F.S.I.; F.S.2 microswitches.

When welder is to be operated by a momentary contact closure without the benefit of a two stage foot switch. Use the following procedure.

- a) Connect a jumper wire on the peripheral board J2-2 to J2-3 to J2-4.
- b) Connect momentary switch between J2-1 and J2-2.

The controller will lock in, start timing and complete sequence.

The contact gage switch is a normally open switch connected to J3-4 and J3-5. It enables the pulses that fire the ignitrons when preset air weld pressure is established.

The water saver output will turn on with the weld valve and will stay on for one minute after FS1 and FS2 have been released or will immediately turn off upon release of FSA.

INTERLOCK SCANNER INTERCONNECTION

Use two twisted pairs of wires to interconnect J5 of model 302A Welding Controller to the "Interlock Scanner" as shown in the wiring diagram.

Set SW2 on the processor board to "ON", otherwise the scanner will be ignored.

Connect "Interlock Scanner" to standard 110V A/C outlet. The scanner provides optical isolation between welding controllers so as to eliminate ground loops.

(NOTE: If welding controllers are operating nearby arc welding machines generating RF in a wide spectrum it is recommended that wires between scanner and welding controllers be installed in water conduits and have the conduits grounded to earth ground.)

WELD SEQUENCE START-UP TEST

It is recommended that start-up and initial check out be done with terminal 1 of the ignitron firing module discounted.

After assurance that the controller is operating the welding machine properly and the TIP arc relay opens during welding time (beginning of Squeeze till end of hold), connect terminal 1 of each ignitron firing module one at a time and verify proper heat control on each phase independently.

REMOTE CONTROL BOX FUNCTIONS AND OPERATION

J2 on the processor board connects a 20 wire flat ribbon cable to the remote control box. The box contains the following functions:

- Repeat:** Repeats sequence with the switch on.
- Weld:** Enables computer in controller to generate weld pulses with the switch on.
- Tip Dress:** Energizes forge valve only when FSA is closed and switch is on.
- Program lock:** This is a switch key removable in either of the two positions. In the lock mode it prevents scanning of weld parameters and thus prevents the operator from changing the program.
- Weld Schedule Selector:** Enables the operator to select 1 of 16 preprogrammed weld schedules. Setting numbers are 0-15. Once a weld schedule is programmed it stays in memory even when power is turned off.
- Next W.S.:** This switch, when on, will convert the weld schedule set by the weld schedule selector as shown on the following page.

From W.S.0 to W.S.1

From W.S.2 to W.S.3

From W.S.4 to W.S.5

From W.S.6 to W.S.7

From W.S.8 to W.S.9

From W.S.10 to W.S.11

From W.S.12 to W.S.13

From W.S.14 to W.S.15

This switch enables jumping back and forth between two weld schedules without the continuous use of the weld schedule selector switch.

POSITIVE, NEGATIVE AND ALTERNATE POLARITY SWITCH

Without this switch the controller will automatically operate in the alternate polarity mode. With a 3 position toggle switch the operator can choose one of three modes of firing a Sciaky type moduwave frequency converter type machine.

SEAM-SPOT-ROLL SWITCH

Without this switch the controller will automatically operate in the spot mode. With a SPDT ON-NONE-ON toggle switch the operator can choose one of two operating modes: Seam & Roll.

NOTE: These two switches can be disabled by a 2 switch minidip switch located in the remote control box. With both switches in the "OFF" position the controller will operate in spot/alternate firing mode.

WELD SCHEDULE SETTING

The remote control operator's box has a hexadecimal 16 position thumbwheel switch called the weld schedule selector.

To best understand this function imagine all the functions seen on the front panel duplicated 16 times. To do so a technique called multiplexing is used. The computer memory is divided into 16 equal sections, each being capable of storing all the variables programmed on the front panel. The thumb wheel switch calls out which section is to be used a given time. All the computer programs are stored in memory (for a period of up to 10 years) when power is turned off.

PROGRAMMABLE TIMING OF EVENTS OF A PREARRANGED SEQUENCE IN A WELD SCHEDULE

Tip Travel Time: Variable from 0 to 99 cycles (1 cycle of time = 1/60 of one second).

Precompression Time: Variable from 0 to 99 cycles.

Squeeze Time: Variable from 0 to 99 cycles.

Impulses: Variable from 0 to 99 impulses (1 impulse = N cool cycles + N heat decay cycles).

Cool Time: Variable from 0 to 99 cycles.

Heat Time: Variable from 0 to 99 cycles.

Heat %: Variable from 0 to 99 %.

Heat Decay Time: Variable from 0 to 99 cycles.

Heat Decay %: Variable from 0 to 99 %.

Hold Time: Variable from 2 to 99 cycles.

Off Time: Variable from 0 to 99 cycles.

NOTE: In rectified D.C. with cool time set to zero minimum allowance setting for heat % is 15%.

FORGE PROGRAM

Forge "HI": Initiates forge valve from beginning of "precompression" till end of halt.

Forge "LOW": Holds forge valve in "OFF" position all the time.

Forge

"Variable": Turns on forge valve during precompression time. Initiates forge delay timer at the beginning of first impulse.

Forge

"Delay Time": Variable from 0 to 99 cycles.

Forge value will be turned on at the end of the forge delay timer and stay on until the end of hold time.

SPOT-SEAM-ROLLSPOT OPERATION

In the spot mode the controller will make a complete sequence, having the weld valve energized from beginning of tip travel time till end of hold time.

In the seam mode the controller will energize the weld valve with activation of FS1, energize motor/clutch output with the activation of FS2, sequence through tip travel, squeeze and continue through cool-heat-heat decay impulses for the duration of the FS1-FS2 foot switch closure. Upon the release of FS1-FS2 the controller will finish the last impulse, continue through hold time and stop and stop in off time. The weld valve and motor/clutch output will de-energize at the end of hold time.

In the rollspot mode the controller will operate through its sequence as in the spot mode. The weld valve will stay energized during "OFF" time allowing the motor to index the part for the next weld. This operation will continue with the repeat switch on and FS1-FS2 closed.

PHASE REVERSAL DURING IMPULSE OPERATION

Phase reversal occurs at the beginning of each impulse (minimum 1 cycle of cool time required). Two LED's on the front panel indicate positive and negative firing.

PROGRAM SETTING

The front panel has a two digit display, a keyboard with the keys 0-9, a * key to the left of digit zero and a red key to the right of digit zero.

In the standby mode the two digit display will indicate the weld schedule selector switch setting. By pushing the "red" key the controller will step out of the standby mode and will display the contents of each function. Observe that each timing function must have a two digit number in the display window. A blank display for a given timing event will lock up the controller in that event for a long time. Return to standby from a timing event by pushing the "*" key. Hold time cannot be set to zero. The controller will always force a minimum of 2 cycles of time. Make sure that the program lock key is in the correct position.

Four buttons adjacent to the functions- heat time, heat %, heat decay time, heat decay %, and make it possible to step into these functions directly without rolling by pushing the red index key. To exit these functions the * exit key must be pushed.

An upper right hand key will change the forge delay mode to one of the three possible settings; HI-LOW-VARIABLE (VAR). In the VAR mode the key below the forge key, called forge delay time, will become active, enabling viewing and changing the contents of forge delay time. The * exit key must be pushed to return to standby mode.

Display digits are moving from right to left so the most significant digit must be entered first.

MAINTENANCE AND PERIPHERAL DIAGNOSTICS

The controller power supply has two incoming fuses on the 110V A/C line, F1 and F2. Both fuses are AGC 1A. One fuse disconnects power from the power supply transformer and the other from the solid state relay powering all valve solenoids.

The Interlock Scanner input and output have one LED each indicating when the controller is transmitting and receiving signals to and from the 5 station Interlock box. The following outputs have LED's indicating the "ON" state of these outputs:

Retraction S.V.

Weld S.V.

Forge S.V.

Tip Arc Relay

Key in S.V.

Motor/Clutch Relay

Water Saver S.V.

Scan Out

The following inputs have LED's indicating signal in or switch closure; FSA, FS1, M.S. (head down), M.S. (key in) and scan in.

RESET ON POWER FAILURE

The controller continuously monitors the power line for severe brownouts. If the line voltage is interrupted or has fallen below a safe operating the controller will halt its operation. Release FSA momentarily. A fail-safe feature does not permit power up with the foot switch engaged. A display with 88 in its window after power up indicates an attempted power up with FSA, FS1 & FS2 closed

3 PHASE LINE VOLTAGE COMPENSATOR MODEL 302L

Installation procedure

Connect 3 wires color coded brown, red and orange through 3 1AMP fuses 600VAC to the power lines.

Connect the brown wire to L1, red to L2 and the orange wire to L3.

This cable connects to the LVC printed circuit board through the connector J1. The high voltage from the power line via the connector J1 is converted to 12 volts AC by the 3 isolation transformers located adjacent to J1 on the printed circuit board. All connections between J1 and the isolation transformers are made on the back side of the printed circuit board. Care should be taken during calibration so that the upper back side of the LVC board is not touched by hands.

Calibration Procedure

The equipment required for LVC calibration is a DC voltmeter set to 10 volts and a jewel type screwdriver.

Connect negative probe of voltmeter to test point T.P.1.

Connect positive probe of voltmeter to the following test points to read the incoming power line voltage :

TP4 reads 2.40VDC if L1 - L2 = 240 VAC

4.80VDC if L1 - L2 = 480 VAC

TP3 reads 2.40VDC if L2 - L3 = 240 VAC

4.80VDC if L2 - L3 = 480 VAC

TP2 reads 2.40VDC if L3 - L1 = 240 VAC

4.80VDC if L3 - L1 = 480 VAC

4.80VDC if L3 - L1 = 480 VAC

Use a jewel screwdriver to adjust potentiometer located below TP5 to 3.20 VDC for a nominal line voltage.

Chart of 3 phase line deviation limit under which the LVC is capable of providing phase angle correction.

HEAT %	LINE VOLTAGE %	LINE VOLTAGE %
	OVER NOMINAL	UNDER NOMINAL
99	03.1%	03.4%
95	04.1%	04.0%
90	05.0%	06.9%
85	07.2%	09.0%
80	08.4%	12.2%
75	10.6%	14.4%
70	11.9%	15.6%
65	15.0%	17.8%
60	15.6%	20.3%
55	15.6%	21.9%
50	15.6%	22.5%
45	15.6%	22.5%
40	15.6%	22.5%
30	15.6%	22.5%
20	15.6%	22.5%
10	15.6%	22.5%

Visual Troubleshooting Display

A red LED marked led 2 is the line input voltage min./max. indicator. Whenever TP5 will drop below 2.48VDC (22.5% below nom.) or above 3.70VDC (15.6% above nom.) LED 2 will turn on. Above or below these limits the LVC will not allow the welding transformer to pass current to the electrodes.

If the line voltage exceeds the limits shown on the chart on page 16 during weld operation a LED marked "out of range" will turn on and a 3 second beeper (optional) will sound an alarm to alert the operator.

The LVC can be turned off by pushing up the LVC ON/OFF switch located below the potentiometer on the printed circuit board. The controller will operate with the same heat level as with the LVC on and the operator will have to make Heat% adjustments to compensate for the excessive line voltage variations at high heat % settings.

OPERATING MODE SETTING

- SW1-1** OFF - ONE PULSE PER CYCLE. FREQUENCY CONVERTER OPERATION.
- ON - ENABLES D.C. OPERATION. THE USE OF WELDING TRANSFORMER WITH 3-PHASE RECTIFIED D.C. ON THE SECONDARY WINDINGS, SET THE CONTROLLER TO FIRE POSITIVE OR NEGATIVE ONLY. THIS WILL CAUSE EACH PHASE TO FIRE TWO PULSES PER CYCLE, POSITIVE AND NEGATIVE. THIS SWITCH MUST NEVER BE SET TO ON DURING ALTERNATE FIRING OPERATION ON FREQUENCY CONVERTER TRANSFORMER.
- SW1-2** OFF - ENABLES LOCKOUT OF ENTIRE FRONT PANEL KEYBOARD WHEN PROGRAM LOCKOUT KEY IS ON.
- ON - ENABLES "HEAT %" AND "HEAT DECAY %" WHEN PROGRAM LOCK IS ON.
- SW1-3** OFF - MOTOR COMES ON WITH SECOND STAGE (FS2).
- ON - MOTOR COMES ON CONCURRENT WITH THE FIRST WELD SPOT.
- SW1-4** OFF - NO FSA BYPASS, IF POWER IS TURNED ON WITH THE RETRACTION FOOT SWITCH AN ERROR MESSAGE (88) WILL BE DISPLAYED.
- ON - WILL DISABLE CONTROL LOCKOUT. THE RETRACTION FOOT SWITCH CONNECTIONS IS TO BE PERMANENTLY MADE BETWEEN FSA & FSA COM. WHEN THE WELDING MACHINE DOES NOT HAVE A RETRACTION POSITION.

MAXIMUM ALLOWABLE NUMBER OF IMPULSES, HEAT TIME AND HEAT DECAY TIME CYCLES

The following procedure is to be implemented, if a maximum limit is to be set for:

1. (cool-heat) IMPULSES
2. HEAT TIME cycles
3. HEAT DECAY TIME cycles

Set minidip SW1-1; SW1-3; SW1-4 to position ON.

Make sure the 302 controller is in the STANDBY mode.

1. Set limit on number of IMPULSES

- a. Push and hold the (*) key on the board.
- b. While holding in the (*) key, push momentary the key (7)
- c. The IMPULSE "led" and the OFF "led" will be flashing
- d. Key in the maximum limit number from 00 - 99, then push the (*) key
- e. If the number entered is other than 00, the controller will limit the data entered to that number.

NOTE: After maximum limit has been set and a number is entered that is higher than that limit, IMPULSES will be set to the maximum limit number and will be displayed for a brief second.

2. Set limit on number of HEAT TIME cycles

- a. Push and hold the (*) key on the board.
- b. While holding in the (*) key, push momentary the key (1)
- c. The HEAT TIME "led" and the OFF "led" will be flashing
- d. Key in the maximum limit number from 00 - 99, then push the (*) key
- e. If the number entered is other than 00, the controller will limit the data entered to that number.

NOTE: After maximum limit has been set and a number is entered that is higher than that limit, HEAT TIME will be set to the maximum limit number and will be displayed for a brief second.

3. Set limit on number of HEAT DECAY TIME cycles

- a. Push and hold the (*) key on the board.
- b. While holding in the (*) key, push momentary the key (4)
- c. The HEAT DECAY TIME "led" and the OFF "led" will be flashing
- d. Key in the maximum limit number from 00 - 99, then push the (*) key
- e. If the number entered is other than 00, the controller will limit the data entered to that number.

NOTE: After maximum limit has been set and a number is entered that is higher than that limit, HEAT DECAY TIME will be set to the maximum limit number and will be displayed for a brief second.

SCHEMATICS

SYSTEM INTERCONNECT DIAGRAM	
1030-092-02	1
REMOTE CONTROL BOX - MODEL 325	
1050-1P1-13	2
PERIPHERAL BOARD MODEL 302A	
1050-102-01	3
30 LVC MODEL 302L	
1050-101-25	4
IGNITRON FIRING MODULE	
1010-087-01	5
30 TRANSFORMER/IGNITRON/FIRING MODULE INTERCONNECT WIRING DIAGRAM	
1010-087-02	6
THREE PHASE SCR CONTACTOR	
1010-087-03	7
PROCESSOR BOARD MODEL 302A PAGE 1	
1050-101-02	8
PROCESSOR BOARD MODEL 302A PAGE 2	
1050-101-01	9
402A IGNITRON FIRING MODULE	
150-022-01	10
THERMAL SWITCH ISOLATION RELAY	
145-002-03	11
ANTITIEDOWN DUAL PALM BUTTON BOARD	
1010-034-02	12
ANTITIEDOWN DUAL PALM BUTTON BOARD	
1010-034-03	13
CONTACTOR FIRING WIRING DIAGRAM	
1010-073-02	14

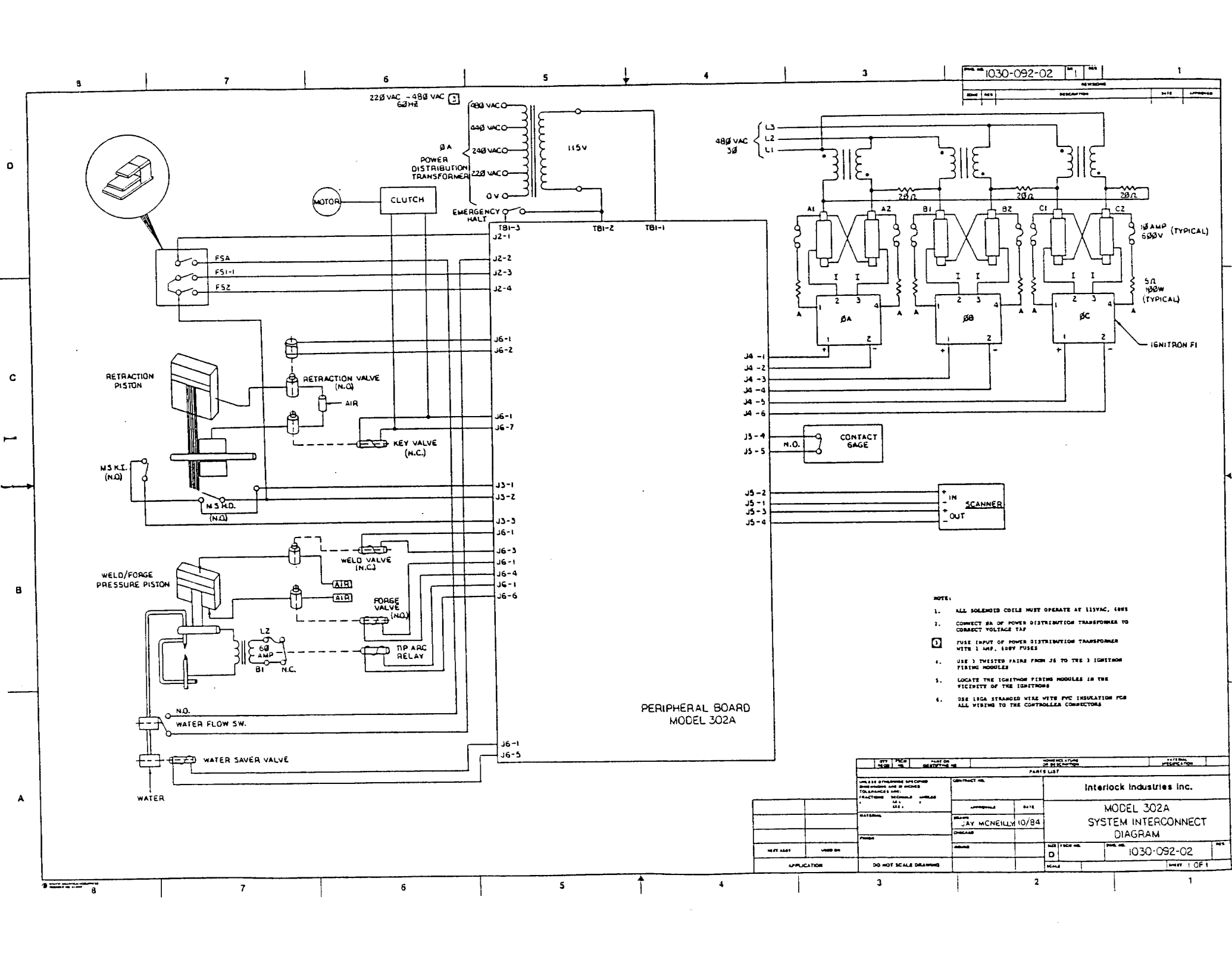

- NOTE:
1. ALL SOLENOID COILS MUST OPERATE AT 115VAC, 480V
 2. CONNECT BA OF POWER DISTRIBUTION TRANSFORMER TO CORRECT VOLTAGE TAP
 3. FUSE INPUT OF POWER DISTRIBUTION TRANSFORMER WITH 1 AMP, 600V FUSES
 4. USE 3 TWISTED PAIRS FROM J5 TO THE 3 IGNITRON FIRING MODULES
 5. LOCATE THE IGNITRON FIRING MODULES IN THE VICINITY OF THE IGNITRONS
 6. USE 18GA STRANDED WIRE WITH PVC INSULATION FOR ALL WIRING TO THE CONTROLLER CONNECTORS

REV		DATE	DESCRIPTION	DATE	APPROVED
PARTS LIST					
UNLESS OTHERWISE SPECIFIED DIMENSIONS ARE IN INCHES TOLERANCES ARE: FRACTIONS DECIMALS MILLIS .001 .01 .05 .1			CONTRACT NO. DATE CHECKED DRAWN MADE BY DATE		
MATERIALS PARTS NEXT ASST MADE BY DATE			Interlock Industries Inc. MODEL 302A SYSTEM INTERCONNECT DIAGRAM REV 1 DATE 1030-092-02 SHEET 1 OF 1		
APPLICATION			DO NOT SCALE DRAWING		

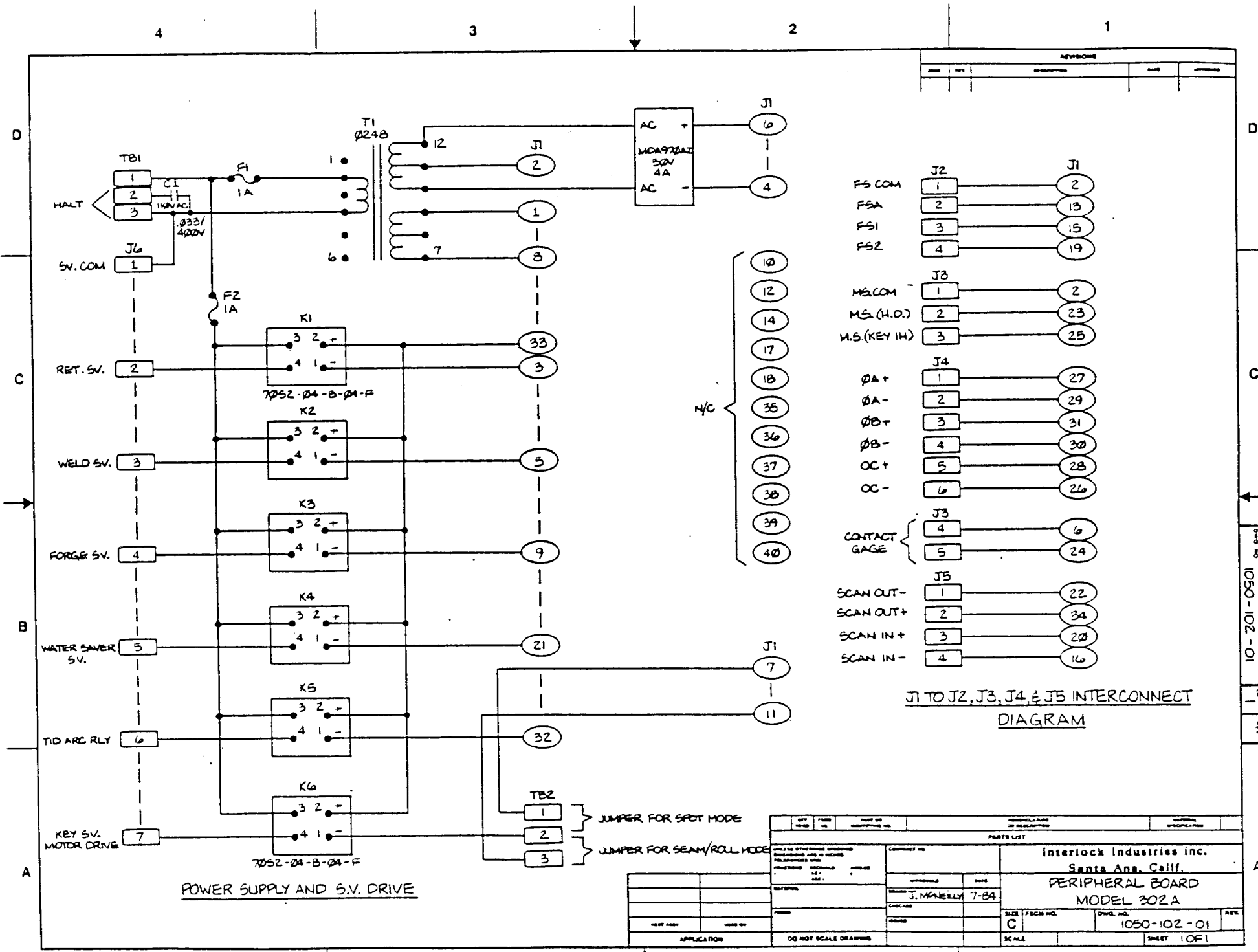

REVISIONS			
NO.	DATE	DESCRIPTION	BY

REV. NO.		DATE		DESCRIPTION		BY	

PARTS LIST			
QTY	ITEM NO.	DESCRIPTION	REVISION

INTERLOCK INDUSTRIES INC. Santa Ana, Calif.		MODEL NO. 1050-102-01	
PERIPHERAL BOARD MODEL 302A		SHEET NO. 1 OF 1	

1050-102-01

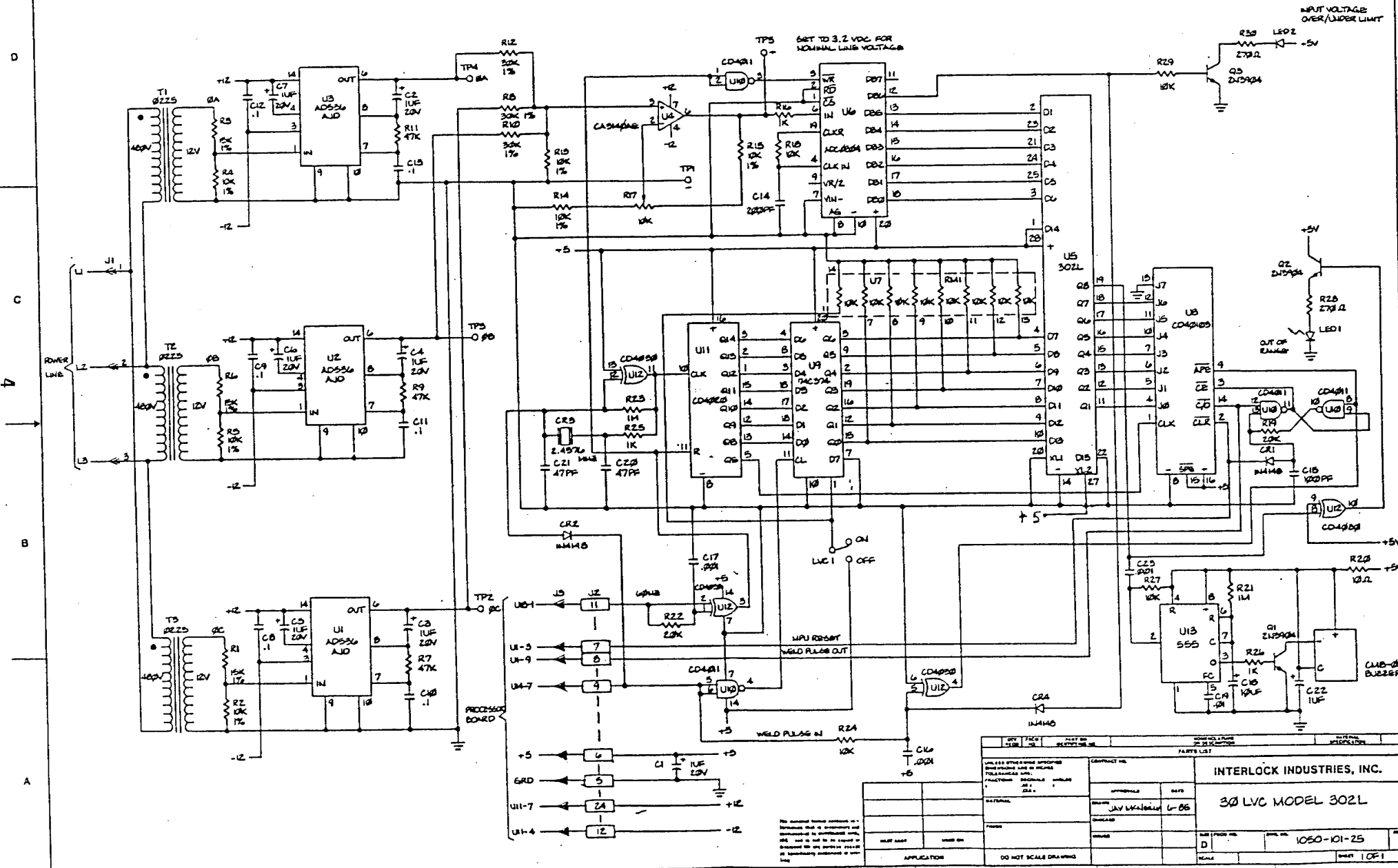

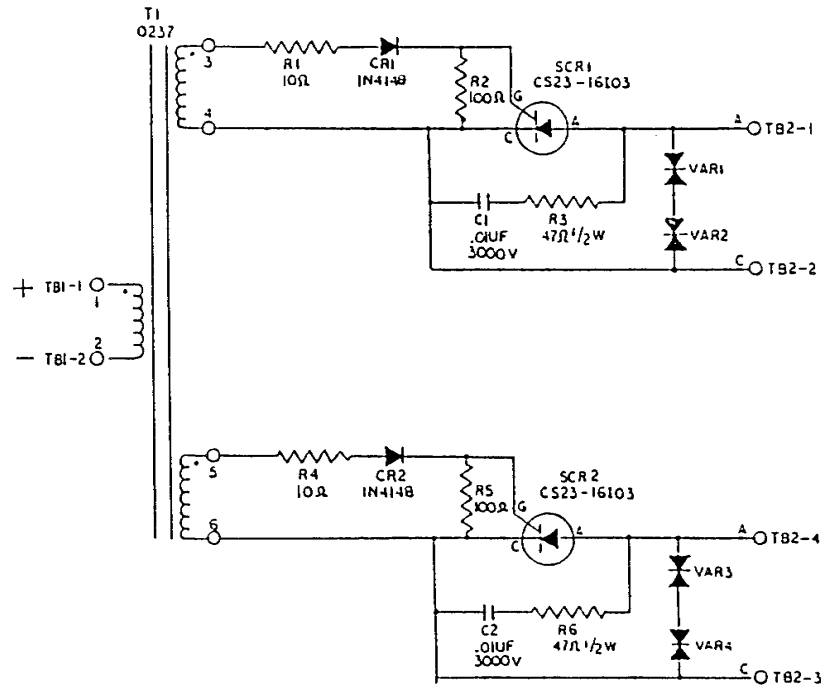

IGNITRON FIRING MODULE		
DATE: 5-5-83	APPROVED BY:	REVISION: 29.
MODEL 402		
INTERLOCK INDUSTRIES INC.		1016-597-01

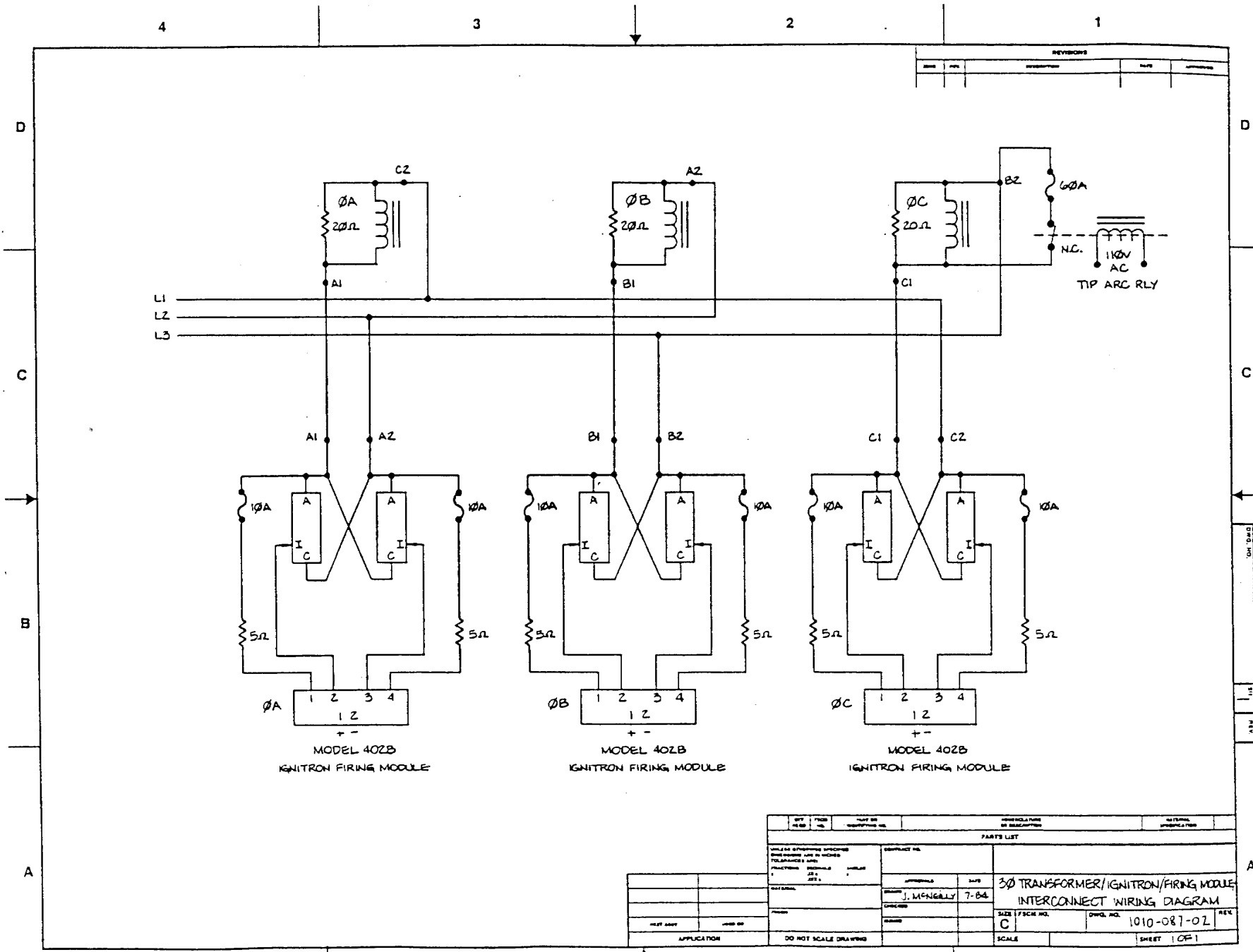

REVISIONS				
NO.	DATE	DESCRIPTION	BY	APPROVED

QTY	PRICE	UNIT	DESCRIPTION	REVISIONS	NO. OF
AS SH.	PER	NO.	OR	NO.	ITEMS
PARTS LIST					
SHALL BE OBTAINED UNLESS OTHERWISE SPECIFIED TOLERANCES & UNITS DIMENSIONS IN INCHES FRACTIONS DECIMALS MILLIMETERS .001" .01" .02" .05" .1" .2" .5" 1"					
DRAWN BY		APPROVED		DATE	
CHECKED		DESIGNED		SCALE	
MATERIAL		PARTS LIST		REV	
NEXT SHEET		USED BY		SHEET	
APPLICATION		DO NOT SCALE DRAWING		SHEET	

3Ø TRANSFORMER/IGNITRON/FIRING MODULE
INTERCONNECT WIRING DIAGRAM

SIZE C DWG. NO. 1010-087-02 REV

SCALE SHEET 1 OF 1

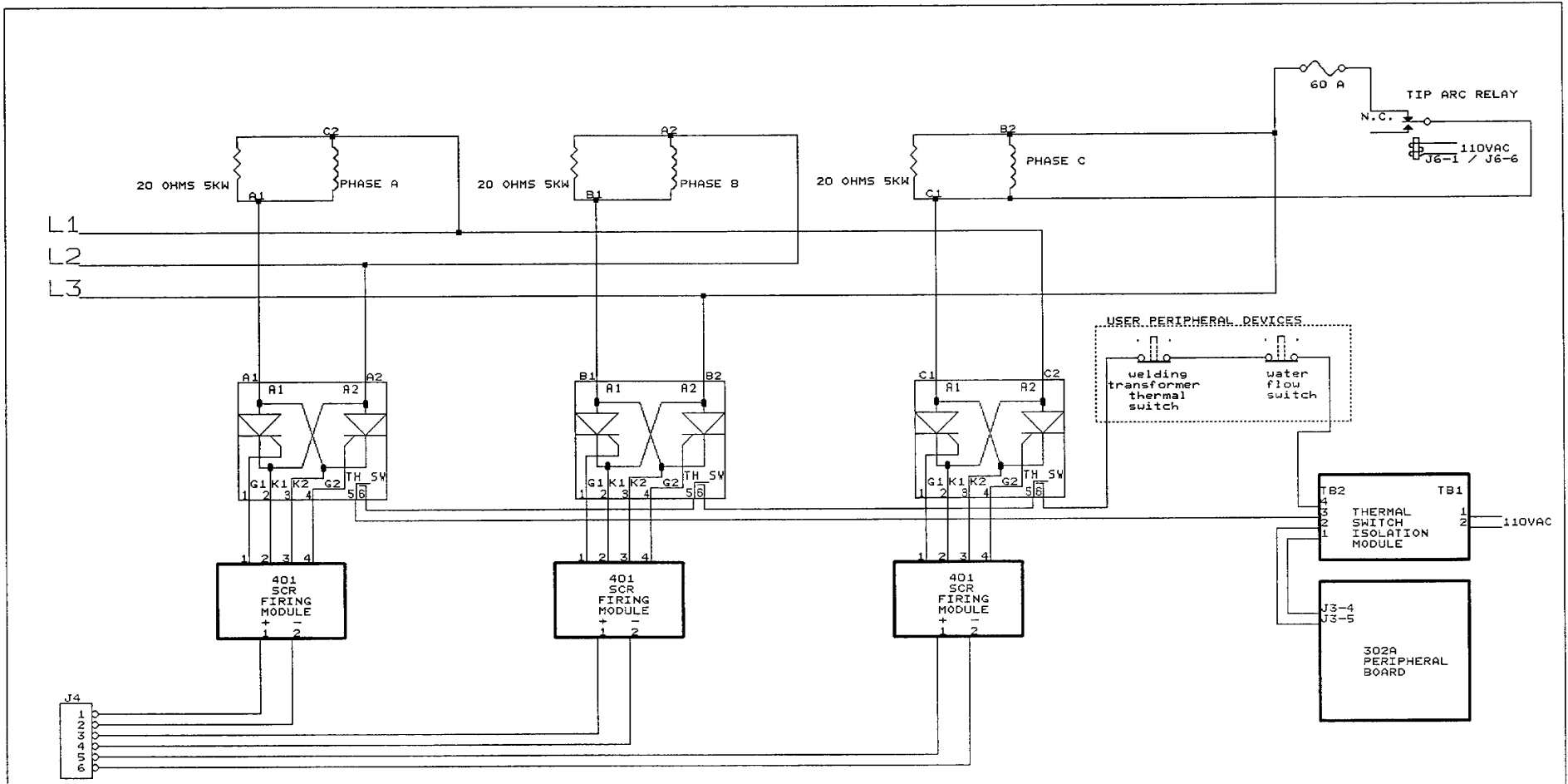

INTERLOCK INDUSTRIES, INC.		
WIRING DIAGRAM		
MODEL 302A		
Title	THREE PHASE SCR CONTACTOR	
Size	Document Number	REV
B	1010-087-03	

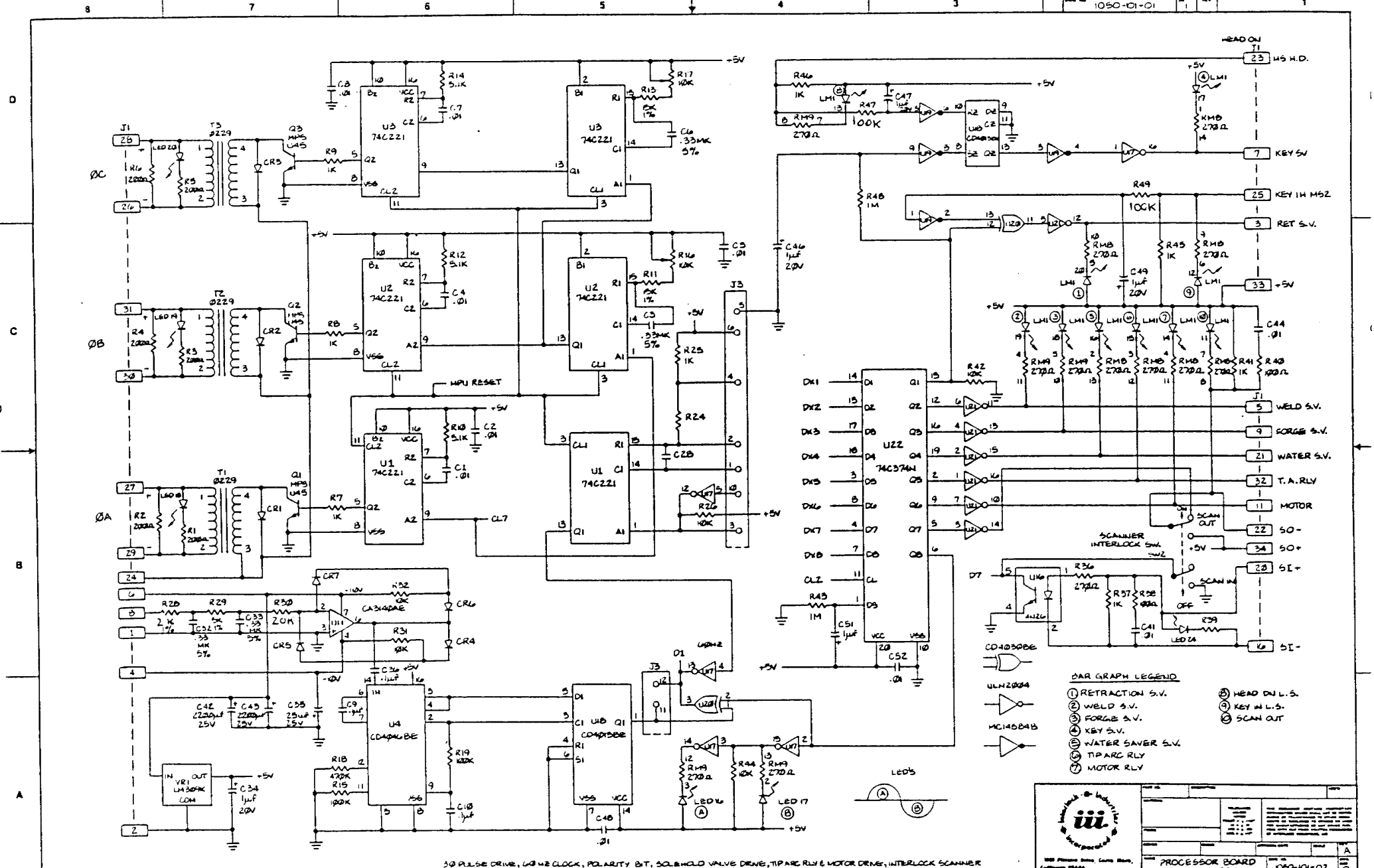

3/2 PULSE DRIVE, 1/40 Hz CLOCK, POLARITY BT, SOLIDSHOLD VALVE DRIVE, TIP ARC RLY & MOTOR DRIVE, INTERLOCK SCANNER

		MODEL 302A PROCESSOR BOARD MODEL 302A	
1050-01-02		1050-01-02	

WELD SCHEDULE MEMORY

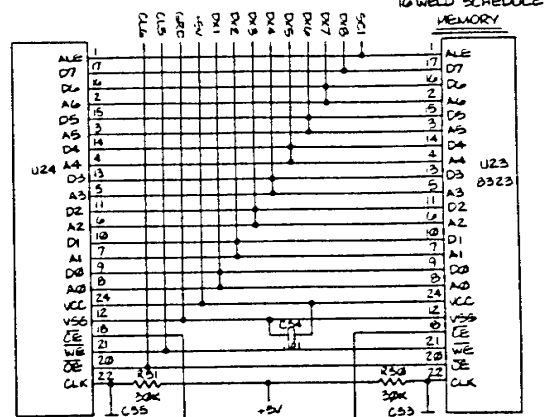

COMPUTER & POWER SUPPLY RESET

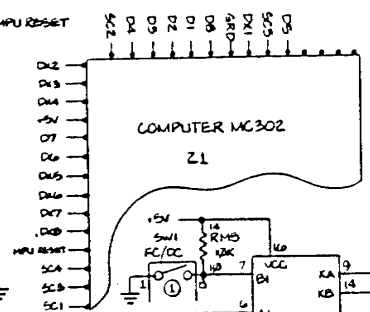

COMPUTER MC302 Z1

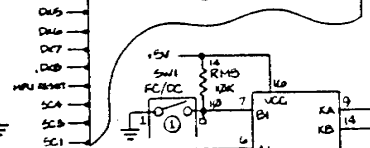

74LS249 (U9)

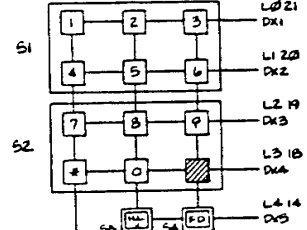
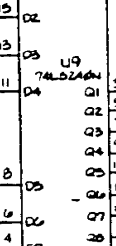

KEYBOARD MATRIX

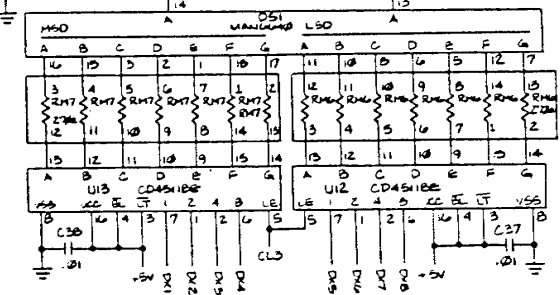

SEQUENTIAL STATES DISPLAY: TWO DIGIT DISPLAY

DATA DEMULTIPLEXER CLOCK GENERATOR

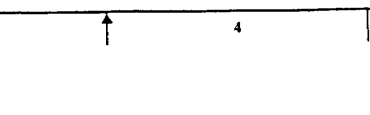

ROOT SWITCH & MODE SELECTOR INPUTS RECEIVER & MULTIPLEXER

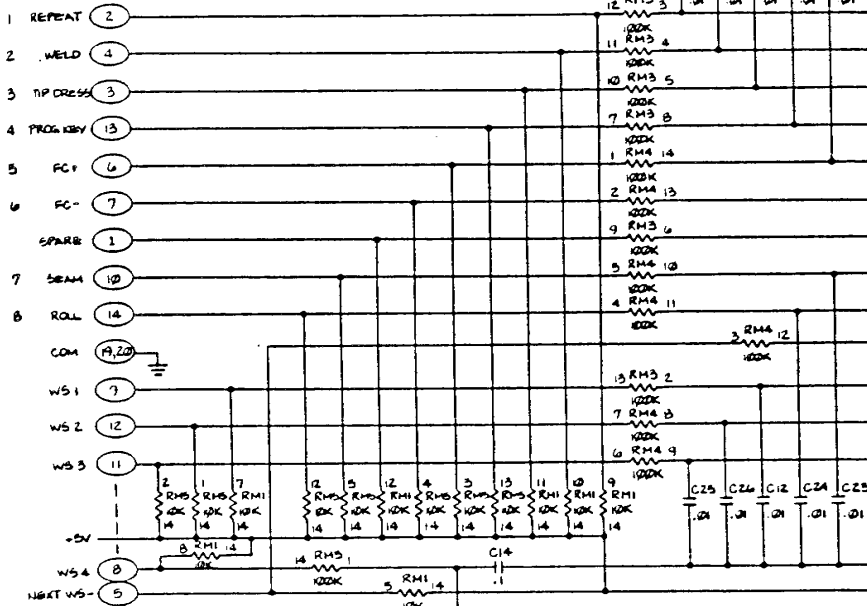
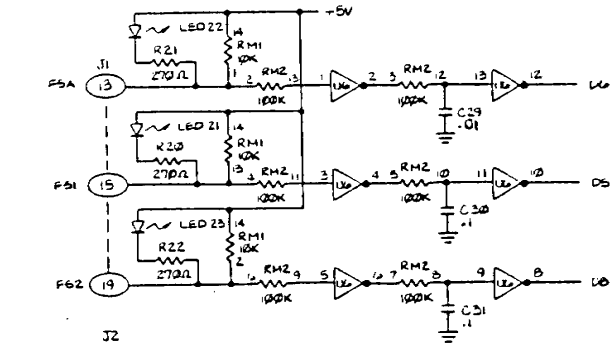

- LED LEGEND
- 1 TIP TRAVEL TIME
 - 2 PRECOMPRESSION TIME
 - 3 DRAZZLE TIME
 - 4 IMP. TIME
 - 5 COOL TIME
 - 6 HEAT TIME
 - 7 HEAT %
 - 8 HEAT DECAY TIME
 - 9 HEAT DECAY %
 - 10 HOLD TIME
 - 11 OFF TIME
 - 12 FORGE DELAY TIME
 - 13 FORGE HI
 - 14 FORGE LOW
 - 15 FORGE VAR

DATE: 1050-01-01

DESIGNER: JAY McNEELY

REV: 1

DATE: 1050-01-01

REV: 1

DATE: 1050-01-01

REV: 1

INTERLOCK INDUSTRIES
MODEL 402A
IGNITRON FIRING MODULE

DARRAH ELECTRIC
IGNITRON REPLACEMENT CONTROLLER

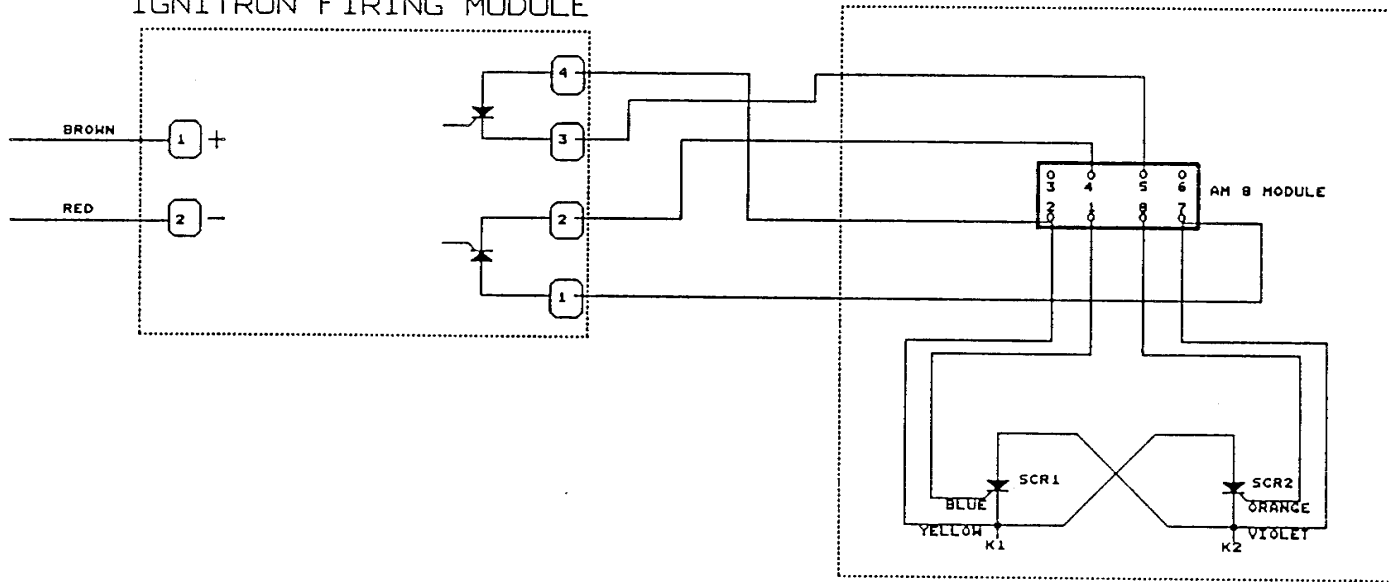

10

INTERLOCK INDUSTRIES, INC.		
DARRAH ELECTRIC IGNITRON REPLACEMENT WIRING DIAGRAM		
Title		
402A IGNITRON FIRING MODULE		
Size Document Number		
B	150-022-01	REV
Date:	July 26, 1991	Sheet 1 of 1

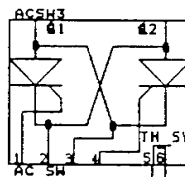
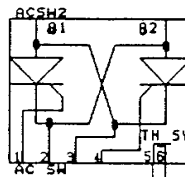
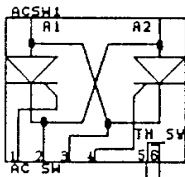
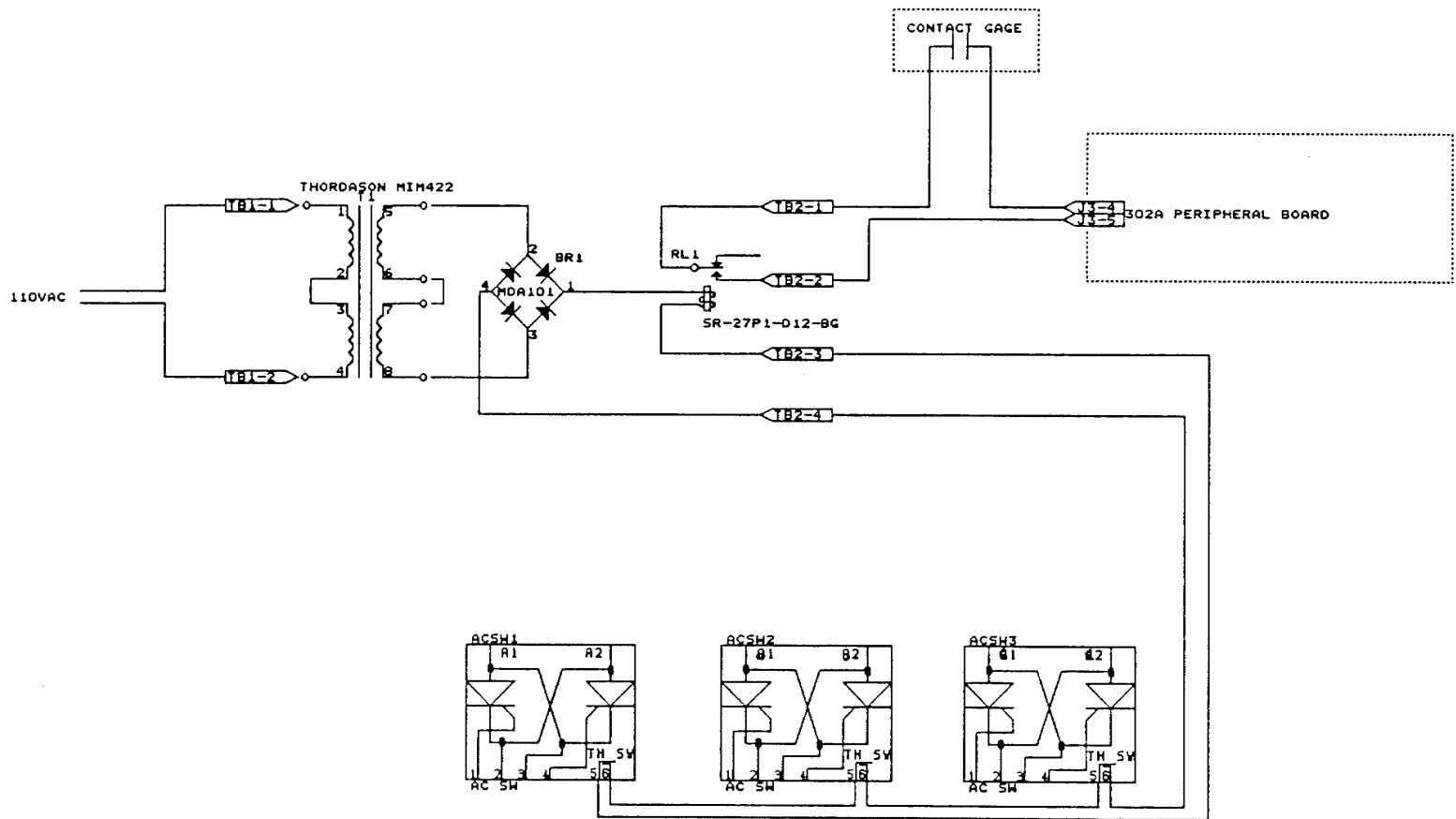

INTERLOCK INDUSTRIES, INC.	
302A CONTROLLER SCR CONTACTORS	
Title THERMAL SWITCH ISOLATION RELAY	
Size	Document Number
B	145-002-03
Date: February 5, 1992	Sheet 1 of 1

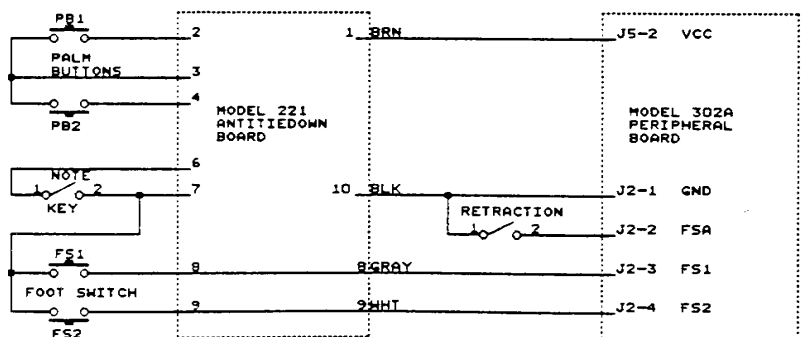
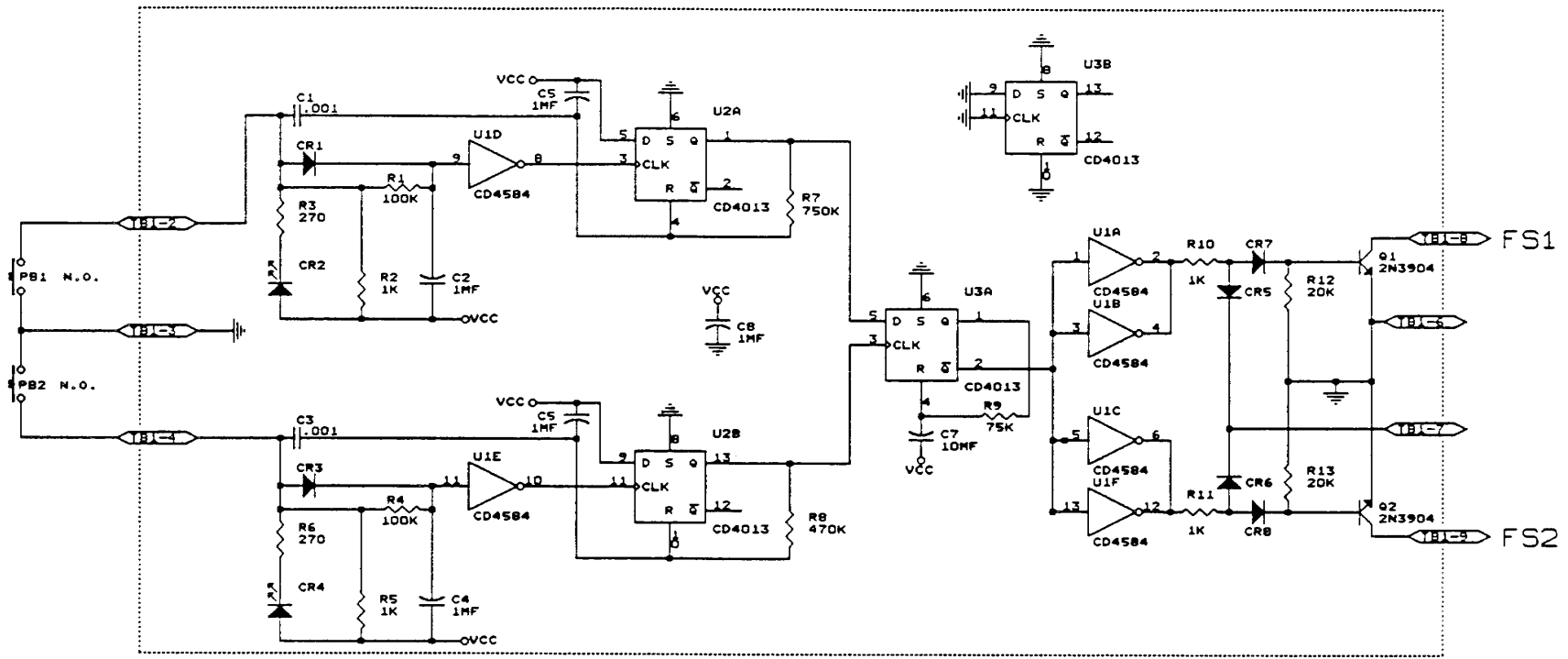

NOTE : KEY SWITCH ON ENABLES FOOT SWITCH AND DISABLES PALM BUTTONS
 CONNECT JUMPER FROM J2-1 TO J2-2 AND TURN ON SW1-4 FOR SYSTEMS WITH NO RETRACTION VALVE

INTERLOCK INDUSTRIES, INC.	
MODEL 221-302	
Title	ANTITIEDOWN DUAL PALM BUTTON BOARD
Size	Document Number
B	1010-034-02
Date:	May 10, 1993 Sheet 1 of 1

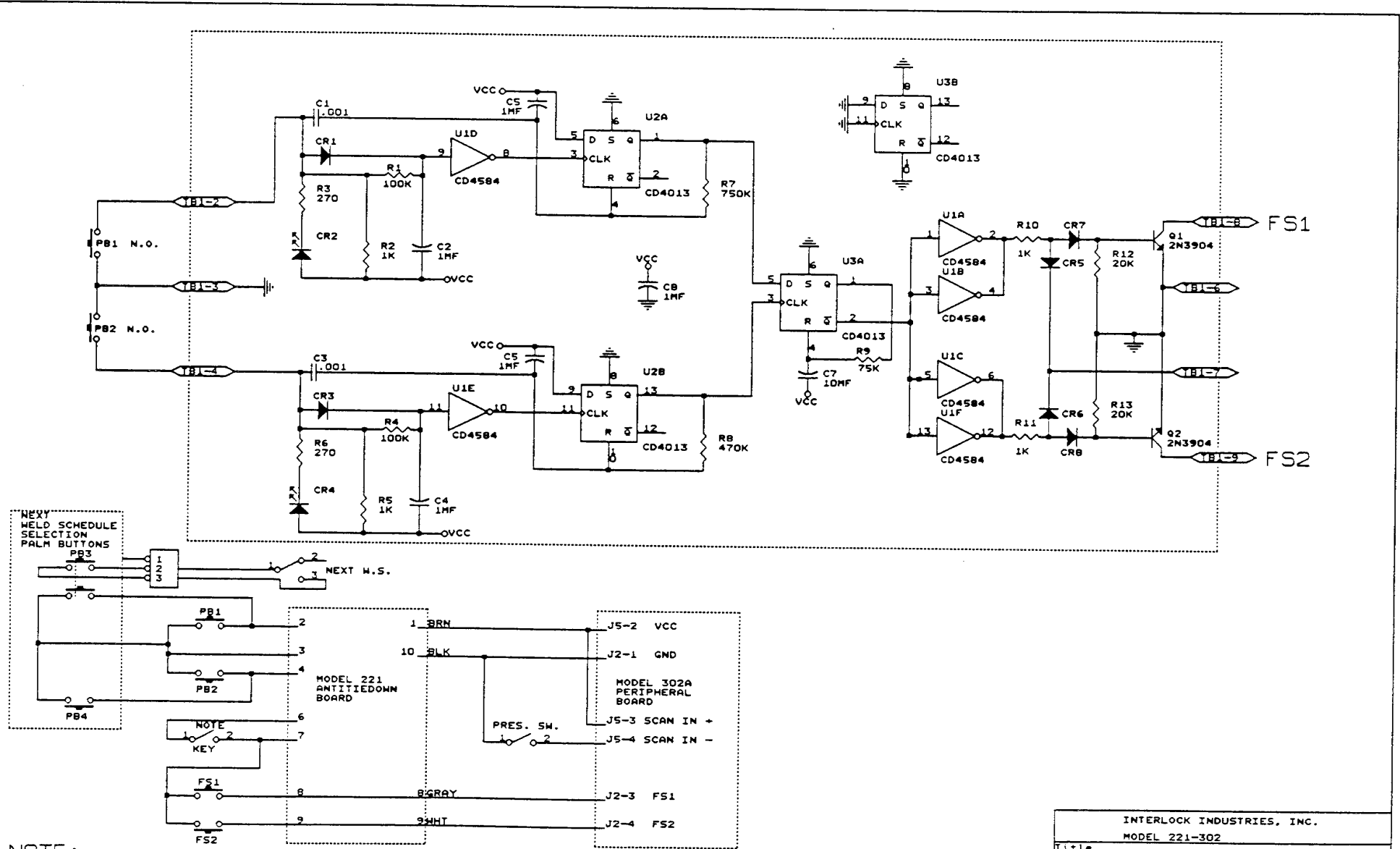

NOTE : KEY SWITCH ON ENABLES FOOT SWITCH AND DISABLES PALM BUTTONS
 TURN ON SW2 SCANNER INTERLOCK SWITCH ON PROCESSOR BOARD TO ENABLE PRESSURE SWITCH INTERLOCK

INTERLOCK INDUSTRIES, INC.	
MODEL 221-302	
Title	ANTITIEDOWN DUAL PALM BUTTON BOARD
Size	Document Number
B	1010-034-03
Date:	May 10, 1993 Sheet 1 of 1

302A CONTROLLER

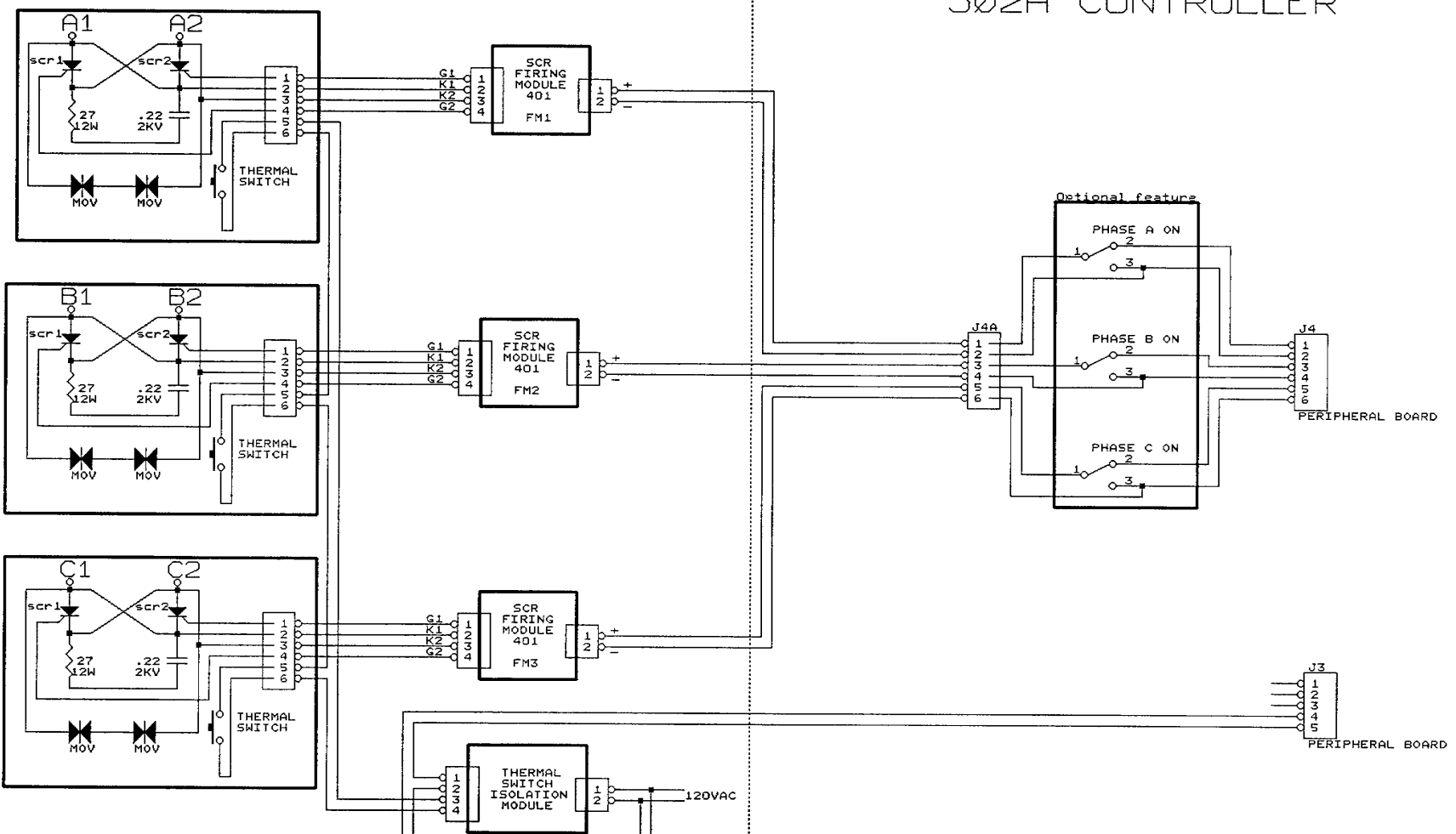

SSAC
TURN ON
TIME DELAY RELAY
P.N. TDML 120AL
SET SOR 2 SECONDS

INTERLOCK INDUSTRIES, INC.		
A-B-C PHASE DISCONNECT THERMAL SWITCH ISOLATION MODULE		
Title		
CONTACTOR FIRING WIRING DIAGRAM		
Size	Document Number	REV
B	1010-073-02	