

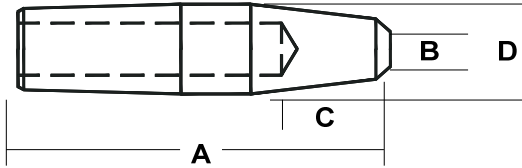

SPOTWELD, INC.

Excellence in Resistance Welding

POINTED



TIP ALLOY		R.W.M.A.	
D	= POINTED NOSE	B	= "B" NOSE
2	= #5RW TAPER	02	= CLASS 2 COPPER
250	= 2.50" LONG	5	= #5RW TAPER
		10	= LENGTH IN 1/4"

POINTED ELECTRODES

	CLASS 2		CLASS 1		CLASS 3		OVERALL LENGTH	WELD FACE DIA.	FACE TO WATER HOLE	MAJOR DIA.
TAPER	#130 CODE	RWMA CODE #	#100 CODE	RWMA CODE #	#200 CODE	RWMA CODE #	A	B	C	D
	P1-100	A02404	P1-100-100	A01404	-	-	1			
	P1-125	A02405	P1-125-100	A01405	P1-125-200	A03405	1-1/4			
	P1-150	A02406	P1-150-100	A01406	P1-150-200	A03406	1-1/2			
4 RW	P1-175	A02407	P1-175-100	A01407	P1-175-200	A03407	1-3/4			
OR	P1-200	A02408	P1-200-100	A01408	P1-200-200	A03408	2			
# 1MT	P1-225	A02409	P1-225-100	A01409	P1-225-200	A03409	2-1/4	3/16	1/2	.482
	P1-250	A02410	P1-250-100	A01410	P1-250-200	A03410	2-1/2			OR
	P1-275	A02411	P1-275-100	A01411	P1-275-200	A03411	2-3/4			.500
	P1-300	A02412	P1-300-100	A01412	P1-300-200	A03412	3			
	P1-325	A02413	P1-325-100	A01413	P1-325-200	A03413	3-1/4			
	P1-350	A02414	P1-350-100	A01414	P1-350-200	A03414	3-1/2			
	P1-375	A02415	P1-375-100	A01415	P1-375-200	A03415	3-3/4			
	P1-400	A02416	P1-400-100	A01416	P1-400-200	A03416	4			
	P2-125	A02505	P2-125-100	A01505	P2-125-200	A03505	1-1/4			
	P2-150	A02506	P2-150-100	A01506	P2-150-200	A03506	1-1/2			
	P2-175	A02507	P2-175-100	A01507	P2-175-200	A03507	1-3/4			
	P2-200	A02508	P2-200-100	A01508	P2-200-200	A03508	2			
5 RW	P2-225	A02509	P2-225-100	A01509	P2-225-200	A03509	2-1/4			
OR	P2-250	A02510	P2-250-100	A01510	P2-250-200	A03510	2-1/2	1/4	3/4	.625
# 2MT	P2-275	A02511	P2-275-100	A01511	P2-275-200	A03511	2-3/4			
	P2-300	A02512	P2-300-100	A01512	P2-300-200	A03512	3			
	P2-325	A02513	P2-325-100	A01513	P2-325-200	A03513	3-1/4			
	P2-350	A02514	P2-350-100	A01514	P2-350-200	A03514	3-1/2			
	P2-375	A02515	P2-375-100	A01515	P2-375-200	A03515	3-3/4			
	P2-400	A02516	P2-400-100	A01516	P2-400-200	A03516	4			
	P6-200	A02608	P6-200-100	A01608	P6-200-200	A03608	2			
6 RW	P6-250	A02610	P6-250-100	A01610	P6-250-200	A03610	2-1/2	9/32	3/4	.750
	P6-300	A02612	P6-300-100	A01612	P6-300-200	A03612	3			
	P3-200	A02708	P3-200-100	A01708	P3-200-200	A03708	2			
7 RW	P3-250	A02710	P3-250-100	A01710	P3-250-200	A03710	2-1/2	5/16	3/4	.875
OR	P3-300	A02712	P3-300-100	A01712	P3-300-200	A03712	3			
# 3MT	P3-400	A02716	P3-400-100	A01716	P3-400-200	A03716	4			



SPOTWELD, INC.

Excellence in Resistance Welding

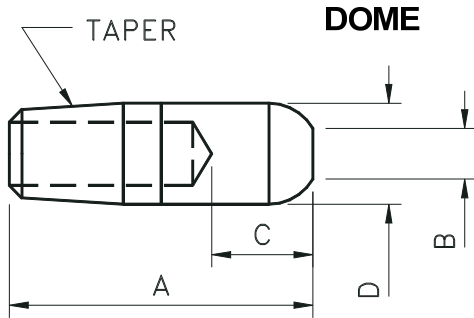

TIPALLOY		R.W.M.A.	
0	= POINTED NOSE	D	= "D" NOSE
2	= #5RW TAPER	02	= CLASS 2 COPPER
250	= 2.50" LONG	5	= #5RW TAPER
		10	= LENGTH IN 1/4"

DOME ELECTRODES

TAPER	CLASS 2		CLASS 1		CLASS 3		OVERALL LENGTH A	WELD FACE DIA. B	FACE TO WATER HOLE C	MAJOR DIA. D
	#130 CODE	RWMA CODE #	#100 CODE	RWMA CODE #	#200 CODE	RWMA CODE #				
4 RW OR # 1MT	P1-100	A02404	P1-100-100	A01404	-	-	1	3/16	1/2	.482 OR .500
	P1-125	A02405	P1-125-100	A01405	P1-125-200	A03405	1-1/4			
	P1-150	A02406	P1-150-100	A01406	P1-150-200	A03406	1-1/2			
	P1-175	A02407	P1-175-100	A01407	P1-175-200	A03407	1-3/4			
	P1-200	A02408	P1-200-100	A01408	P1-200-200	A03408	2			
	P1-225	A02409	P1-225-100	A01409	P1-225-200	A03409	2-1/4			
	P1-250	A02410	P1-250-100	A01410	P1-250-200	A03410	2-1/2			
	P1-275	A02411	P1-275-100	A01411	P1-275-200	A03411	2-3/4			
	P1-300	A02412	P1-300-100	A01412	P1-300-200	A03412	3			
	P1-325	A02413	P1-325-100	A01413	P1-325-200	A03413	3-1/4			
	P1-350	A02414	P1-350-100	A01414	P1-350-200	A03414	3-1/2			
	P1-375	A02415	P1-375-100	A01415	P1-375-200	A03415	3-3/4			
P1-400	A02416	P1-400-100	A01416	P1-400-200	A03416	4				
5 RW OR # 2MT	P2-125	A02505	P2-125-100	A01505	P2-125-200	A03505	1-1/4	1/4	3/4	.625
	P2-150	A02506	P2-150-100	A01506	P2-150-200	A03506	1-1/2			
	P2-175	A02507	P2-175-100	A01507	P2-175-200	A03507	1-3/4			
	P2-200	A02508	P2-200-100	A01508	P2-200-200	A03508	2			
	P2-225	A02509	P2-225-100	A01509	P2-225-200	A03509	2-1/4			
	P2-250	A02510	P2-250-100	A01510	P2-250-200	A03510	2-1/2			
	P2-275	A02511	P2-275-100	A01511	P2-275-200	A03511	2-3/4			
	P2-300	A02512	P2-300-100	A01512	P2-300-200	A03512	3			
	P2-325	A02513	P2-325-100	A01513	P2-325-200	A03513	3-1/4			
	P2-350	A02514	P2-350-100	A01514	P2-350-200	A03514	3-1/2			
	P2-375	A02515	P2-375-100	A01515	P2-375-200	A03515	3-3/4			
	P2-400	A02516	P2-400-100	A01516	P2-400-200	A03516	4			
6 RW	P6-200	A02608	P6-200-100	A01608	P6-200-200	A03608	2	9/32	3/4	.750
	P6-250	A02610	P6-250-100	A01610	P6-250-200	A03610	2-1/2			
	P6-300	A02612	P6-300-100	A01612	P6-300-200	A03612	3			
7 RW OR # 3MT	P3-200	A02708	P3-200-100	A01708	P3-200-200	A03708	2	5/16	3/4	.875
	P3-250	A02710	P3-250-100	A01710	P3-250-200	A03710	2-1/2			
	P3-300	A02712	P3-300-100	A01712	P3-300-200	A03712	3			
	P3-400	A02716	P3-400-100	A01716	P3-400-200	A03716	4			



SPOTWELD, INC.

Excellence in Resistance Welding

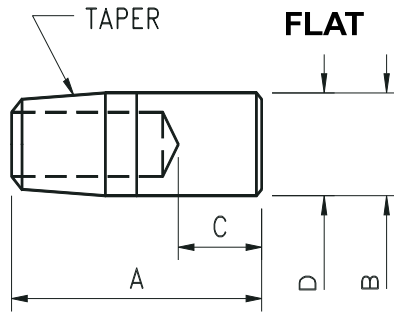

EXAMPLE OF PART CODING:			
TIP/ALLOY		R.W.M.A.	
F	= POINTED NOSE	C	= "C" NOSE
2	= #5RW TAPER	02	= CLASS 2 COPPER
250	= 2.50" LONG	5	= #5RW TAPER
		10	= LENGTH IN 1/4"

FLAT ELECTRODES

	CLASS 2		CLASS 1		CLASS 3		OVERALL	WELD	FACE TO	MAJOR
	#130	RWMA	#100	RWMA	#200	RWMA	LENGTH	FACE	WATER	DIA.
TAPER	CODE	CODE #	CODE	CODE #	CODE	CODE #	A	DIA.	HOLE	D
	F1-100	C02404	F1-100-100	C01404	-	-	1			
	F1-125	C02405	F1-125-100	C01405	F1-125-200	C03405	1-1/4			
	F1-150	C02406	F1-150-100	C01406	F1-150-200	C03406	1-1/2			
4 RW	F1-175	C02407	F1-175-100	C01407	F1-175-200	C03407	1-3/4			
OR	F1-200	C02408	F1-200-100	C01408	F1-200-200	C03408	2			
# 1MT	F1-225	C02409	F1-225-100	C01409	F1-225-200	C03409	2-1/4	3/16	1/2	.482
	F1-250	C02410	F1-250-100	C01410	F1-250-200	C03410	2-1/2			OR
	F1-275	C02411	F1-275-100	C01411	F1-275-200	C03411	2-3/4			.500
	F1-300	C02412	F1-300-100	C01412	F1-300-200	C03412	3			
	F1-325	C02413	F1-325-100	C01413	F1-325-200	C03413	3-1/4			
	F1-350	C02414	F1-350-100	C01414	F1-350-200	C03414	3-1/2			
	F1-375	C02415	F1-375-100	C01415	F1-375-200	C03415	3-3/4			
	F1-400	C02416	F1-400-100	C01416	F1-400-200	C03416	4			
	F2-125	C02505	F2-125-100	C01505	F2-125-200	C03505	1-1/4			
	F2-150	C02506	F2-150-100	C01506	F2-150-200	C03506	1-1/2			
	F2-175	C02507	F2-175-100	C01507	F2-175-200	C03507	1-3/4			
	F2-200	C02508	F2-200-100	C01508	F2-200-200	C03508	2			
5 RW	F2-225	C02509	F2-225-100	C01509	F2-225-200	C03509	2-1/4			
OR	F2-250	C02510	F2-250-100	C01510	F2-250-200	C03510	2-1/2	1/4	3/4	.625
# 2MT	F2-275	C02511	F2-275-100	C01511	F2-275-200	C03511	2-3/4			
	F2-300	C02512	F2-300-100	C01512	F2-300-200	C03512	3			
	F2-325	C02513	F2-325-100	C01513	F2-325-200	C03513	3-1/4			
	F2-350	C02514	F2-350-100	C01514	F2-350-200	C03514	3-1/2			
	F2-375	C02515	F2-375-100	C01515	F2-375-200	C03515	3-3/4			
	F2-400	C02516	F2-400-100	C01516	F2-400-200	C03516	4			
	F6-200	C02608	F6-200-100	C01608	F6-200-200	C03608	2			
6 RW	F6-250	C02610	F6-250-100	C01610	F6-250-200	C03610	2-1/2	9/32	3/4	.750
	F6-300	C02612	F6-300-100	C01612	F6-300-200	C03612	3			
	F3-200	C02708	F3-200-100	C01708	F3-200-200	C03708	2			
	F3-250	C02710	F3-250-100	C01710	F3-250-200	C03710	2-1/2	5/16	3/4	.875
# 3MT	F3-300	C02712	F3-300-100	C01712	F3-300-200	C03712	3			
	F3-400	C02716	F3-400-100	C01716	F3-400-200	C03716	4			



SPOTWELD, INC.

Excellence in Resistance Welding

EXAMPLE OF PART CODING:			
TIP ALLOY		R.W.M.A.	
0	= POINTED NOSE	D	= "D" NOSE
2	= #5RW TAPER	02	= CLASS 2 COPPER
250	= 2.50" LONG	5	= #5RW TAPER
		10	= LENGTH IN 1/4"

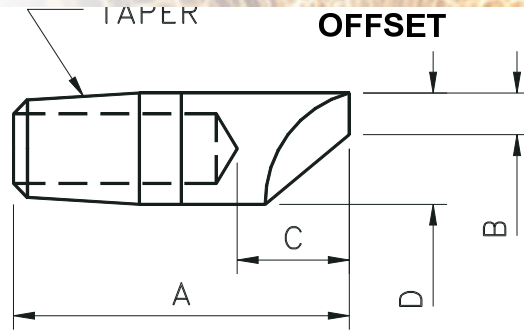

	CLASS 2		CLASS 1		CLASS 3		OVERALL	WELD	FACE TO	MAJOR
	#130	RWMA	#100	RWMA	#200	RWMA	LENGTH	FACE	WATER	DIA.
TAPER	CODE	CODE #	CODE	CODE #	CODE	CODE #	A	B	C	D
	01-100	D02404	01-100-100	D01404	-	-	1			
	01-125	D02405	01-125-100	D01405	01-125-200	D03405	1-1/4			
	01-150	D02406	01-150-100	D01406	01-150-200	D03406	1-1/2			
4 RW	01-175	D02407	01-175-100	D01407	01-175-200	D03407	1-3/4			
OR	01-200	D02408	01-200-100	D01408	01-200-200	D03408	2			
# 1MT	01-225	D02409	01-225-100	D01409	01-225-200	D03409	2-1/4	3/16	1/2	.482
	01-250	D02410	01-250-100	D01410	01-250-200	D03410	2-1/2			OR
	01-275	D02411	01-275-100	D01411	01-275-200	D03411	2-3/4			.500
	01-300	D02412	01-300-100	D01412	01-300-200	D03412	3			
	01-325	D02413	01-325-100	D01413	01-325-200	D03413	3-1/4			
	01-350	D02414	01-350-100	D01414	01-350-200	D03414	3-1/2			
	01-375	D02415	01-375-100	D01415	01-375-200	D03415	3-3/4			
	01-400	D02416	01-400-100	D01416	01-400-200	D03416	4			
	02-125	D02505	02-125-100	D01505	02-125-200	D03505	1-1/4			
	02-150	D02506	02-150-100	D01506	02-150-200	D03506	1-1/2			
	02-175	D02507	02-175-100	D01507	02-175-200	D03507	1-3/4			
	02-200	D02508	02-200-100	D01508	02-200-200	D03508	2			
5 RW	02-225	D02509	02-225-100	D01509	02-225-200	D03509	2-1/4			
OR	02-250	D02510	02-250-100	D01510	02-250-200	D03510	2-1/2	1/4	3/4	.625
# 2MT	02-275	D02511	02-275-100	D01511	02-275-200	D03511	2-3/4			
	02-300	D02512	02-300-100	D01512	02-300-200	D03512	3			
	02-325	D02513	02-325-100	D01513	02-325-200	D03513	3-1/4			
	02-350	D02514	02-350-100	D01514	02-350-200	D03514	3-1/2			
	02-375	D02515	02-375-100	D01515	02-375-200	D03515	3-3/4			
	02-400	D02516	02-400-100	D01516	02-400-200	D03516	4			
	06-200	D02608	06-200-100	D01608	06-200-200	D03608	2			
6 RW	06-250	D02610	06-250-100	D01610	06-250-200	D03610	2-1/2	9/32	3/4	.750
	06-300	D02612	06-300-100	D01612	06-300-200	D03612	3			
	03-200	D02708	03-200-100	D01708	03-200-200	D03708	2			
7 RW	03-250	D02710	03-250-100	D01710	03-250-200	D03710	2-1/2	5/16	3/4	.875
OR	03-300	D02712	03-300-100	D01712	03-300-200	D03712	3			
# 3MT	03-400	D02716	03-400-100	D01716	03-400-200	D03716	4			

OFFSET ELECTRODES



RADIUS AND TRUNCATED TIPS

RADIUS AND TRUNCATED TIPS

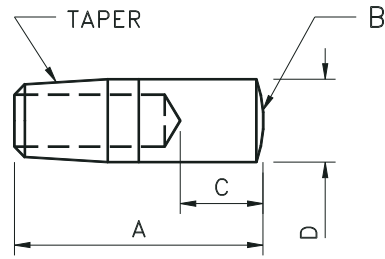

RADIUS

	#130 CODE NO.	#100 CODE NO.	OVERALL LENGTH	WELD FACE DIA.	FACE TO WATER HOLE	MAJOR DIAMETER
	CLASS 2	CLASS 1	A	B	C	D
4RW / #1MT	TC-244	TC-144	1	3/16	.500	.482 OR 0.5
	TC-246	TC-146	1-1/2			
	TC-248	TC-148	2			
	TC-2410	TC-1410	2-1/2			
	TC-2412	TC-1412	3			
5RW / #2MT	TC-256	TC-156	1-1/2	1/4	3/4	.625
	TC-258	TC-158	2			
	TC-2510	TC-1510	2-1/2			
	TC-2512	TC-1512	3			
	TC-2514	TC-1514	3-1/2			
	TC-2516	TC-1516	4			
7RW / #3MT	TC-278	TC-178	2	5/16	3/4	.875
	TC-2712	TC-1712	3			
	TC-2716	TC-1716	4			

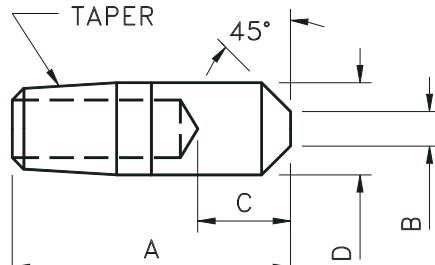

TRUNCATED

	#130 CODE NO.	#100 CODE NO.	OVERALL LENGTH	WELD FACE DIA.	FACE TO WATER HOLE	MAJOR DIAMETER
	CLASS 2	CLASS 1	A	B	C	D
4RW / #1MT	TC-244	TC-144	1	3/16	.500	.482 OR 0.5
	TC-246	TC-146	1-1/2			
	TC-248	TC-148	2			
	TC-2410	TC-1410	2-1/2			
	TC-2412	TC-1412	3			
5RW / #2MT	TC-256	TC-156	1-1/2	1/4	3/4	.625
	TC-258	TC-158	2			
	TC-2510	TC-1510	2-1/2			
	TC-2512	TC-1512	3			
	TC-2514	TC-1514	3-1/2			
	TC-2516	TC-1516	4			
7RW / #3MT	TC-278	TC-178	2	5/16	3/4	.875
	TC-2712	TC-1712	3			
	TC-2716	TC-1716	4			



CT FACED & OFFSET ELECTRODES

CT FACED & OFFSET ELECTRODES

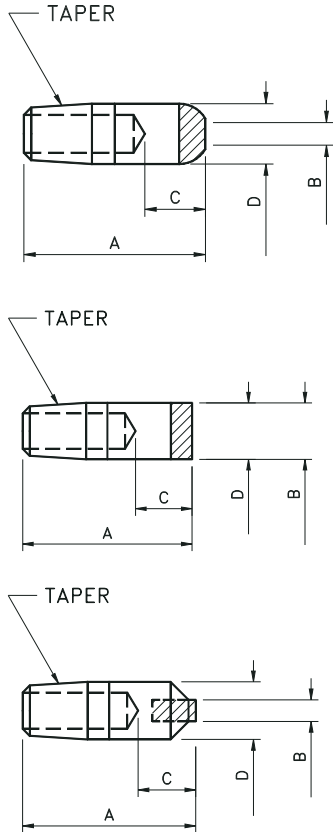

TAPER	T10W CU/TUNG FACING CODE NO.	T100W TUNGSTEN FACING CODE NO.	T100M MOLLY FACING CODE NO.	OVERALL LENGTH A	WELD FACE DIA. B	FACE TO WATER HOLE C	MAJOR DIA. D
DOME - CT FACED							
4RW / #1MT	CT-1578	CT-1577	M-1579	2	1/8	3/8	.500
5RW / #2MT	CT-1581	CT-1580	M-1582		1/8		.625
7RW / #3MT	CT-1584	CT-1583	M-1585		1/4		.875
FLAT - CT FACED							
4RW / #1MT	CT-1587	CT-1586	M-1588	2	1/2	3/8	.500
5RW / #2MT	CT-1590	CT-1589	M-1591		5/8		.625
7RW / #3MT	CT-1593	CT-1592	M-1594		7/8		.875
CENTER INSERTED							
4RW / #1MT	H-147400	CT-147400	M-147400	2	3/16	1/2	.500
5RW / #2MT	H-147500	CT-147500	M-147500		1/4	9/16	.625
7RW / #3MT	H-147600	CT-147600	M-147600		3/8	11/16	.875

COPPER TUNGSTEN, TUNGSTEN, AND MOLYBDENUM ARE ALSO AVAILABLE IN CUT-TO-LENGTH INSERTS, IN 8" OR 12" LENGTHS, AND IN ROUND OR RECTANGULAR SHAPES.

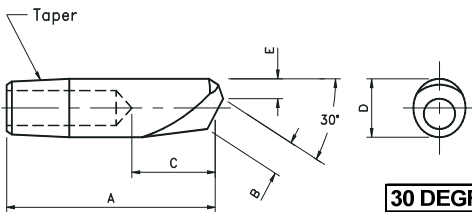

30 DEGREE OFFSET						
TAPER	#130 CODE NO.	LENGTH TO CENTER OF FACE A	WELD FACE DIA. B	FACE TO WATER HOLE C	MAJOR DIA. D	CLEARANCE DISTANCE E
4RW / #1MT	SP-219-1	2	1/4		.482 / .500	3/16
5RW / #2MT	SP-219-2	2-1/2	3/8	2-1/2	0.625	1/4
7RW / #3MT	SP-219-3	3	1/2		0.875	5/16

SPECIAL OFFSET TIPS CAN BE MANUFACTURED TO YOUR SPECIFICATIONS INCLUDING BUTTON STYLE, LOW PROFILE-ELECTRODE TAPER STYLE, AND VARIATIONS OF THE STANDARDS SHOWN ABOVE.



MALE CAP TIPS AND SHANKS

MALE CAP TIPS

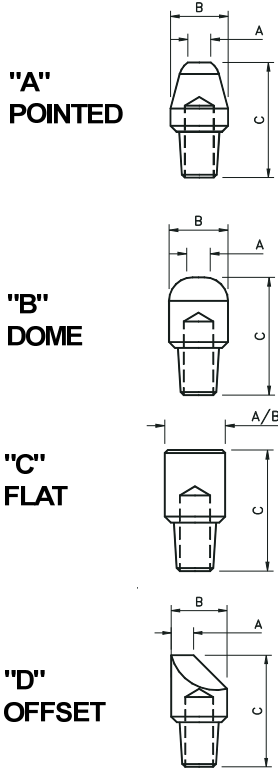

TAPER	ALLOY #100 CLASS 1	ALLOY #130 CLASS 2	ALLOY #Z169 Zr/Cu.	ALLOY #200 CLASS 3	WELD FACE DIA.	MAJOR DIA.	OVERALL LENGTH
					A	B	C
"A" Nose (Pointed)							
4 RWMC	CA-14	CA-24	CA-Z4	CA-34	3/16	1/2	1-1/8
5 RWMC	CA-15	CA-25	CA-Z5	CA-35	1/4	5/8	1-1/4
7 RWMC	-	CA-27	-	-	5/16	7/8	1-5/8
"B" Nose (Dome)							
4 RWMC	CB-14	CB-24	CB-Z4	CB-34	3/16	1/2	1-1/8
5 RWMC	CB-15	CB-25	CB-Z5	CB-35	1/4	5/8	1-1/4
7 RWMC	-	CB-27	-	-	5/16	7/8	1-5/8
"C" Nose (Flat)							
4 RWMC	CC-14	CC-24	CC-Z4	CC-34	1/2	1/2	1-1/8
5 RWMC	CC-15	CC-25	CC-Z5	CC-35	5/8	5/8	1-1/4
7 RWMC	-	CC-27	-	-	7/8	7/8	1-5/8
"D" Nose (Offset)							
4 RWMC	CD-14	CD-24	CD-Z4	CD-34	3/16	1/2	1-1/8
5 RWMC	CD-15	CD-25	CD-Z5	CD-35	1/4	5/8	1-1/4
7 RWMC	-	CD-27	-	-	5/16	7/8	1-5/8

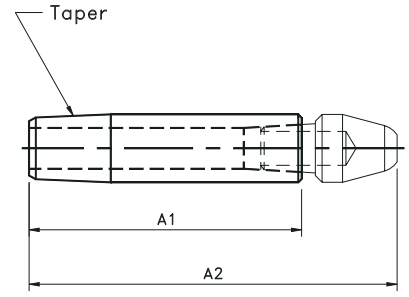
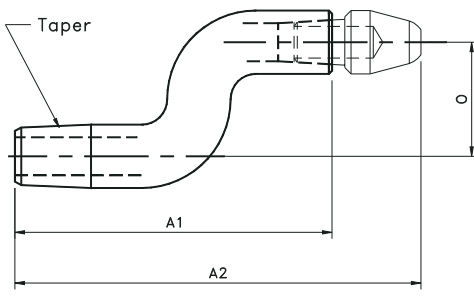

5 RW Taper Code No.	Shank Length A1	Ass'y Length A2	Tip Offset O
Alloy #130			
OS-2528-4	2-1/2	3-1/4	1/4
OS-2528-8	2-1/2	3-1/4	1/2
OS-2534-16	3-1/4	4	1
OS-25212-20	2-3/4	3-1/2	1-1/4
OS-25312-24	3-3/4	4-1/2	1-1/2
OS-25212-28	2-3/4	3-1/2	1-3/4
OS-25314-40	3-7/8	4-5/8	2-1/2
OS-2534-32	3-1/4	4	2

4 RW TAPER (#1MT)	5 RW TAPER (#2MT)	SHANK LENGTH A1	ASSY. LENGTH A2
CS-245	CS-255	1-1/4	2
CS-246	CS-256	1-1/2	2-1/4
CS-247	CS-257	1-3/4	2-1/2
CS-248	CS-258	2	2-3/4
CS-249	CS-259	2-1/4	3
CS-2410	CS-2510	2-1/2	3-1/4
CS-2411	CS-2511	2-3/4	3-1/2
CS-2412	CS-2512	3	3-3/4
CS-2413	CS-2513	3-1/4	4



FEMALE CAP TIPS

RWMA Female Cap Tape	Alloy #130 Class 2	Alloy Z#169 Zirc. Cu.	Alloy "G" Glidcop	Weld Face A	Major Diameter B	Overall Length C
"A" Nose (Pointed)						
4 RW	CAF-24	CAF-Z4	CAF-G4	3/16	1/2	0.84
5 RW	CAF-25	CAF-Z5	CAF-G5	1/4	5/8	0.88
6 RW	CAF-26	CAF-Z6	CAF-G6	9/32	3/4	1
"B" Nose (Dome)						
4 RW	CBF-24	CBF-Z4	CBF-G4	3/16	1/2	0.84
5 RW	CBF-25	CBF-Z5	CBF-G5	1/4	5/8	0.88
6 RW	CBF-26	CBF-Z6	CBF-G6	9/32	3/4	1
"C" Nose (Flat)						
4 RW	CCF-24	CCF-Z4	CCF-G4	1/2	1/2	0.84
5 RW	CCF-25	CCF-Z5	CCF-G5	5/8	5/8	0.88
6 RW	CCF-26	CCF-Z6	CCF-G6	3/4	3/4	1
"D" Nose (Offset)						
4 RW	CDF-24	CDF-Z4	CDF-G4	3/16	1/2	0.84
5 RW	CDF-25	CDF-Z5	CDF-G5	1/4	5/8	0.88
6 RW	-	-	-	9/32	3/4	1

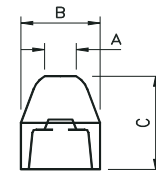

CAF
(POINTED)

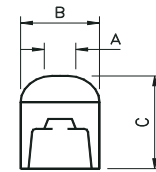

CBF
(DOME)

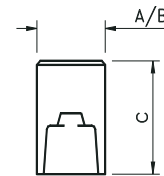

CCF
(FLAT)

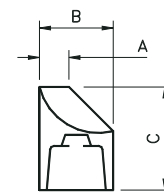

CDF
(OFFSET)

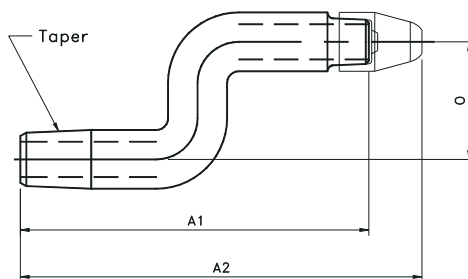

OFFSET FEMALE CAP SHANKS

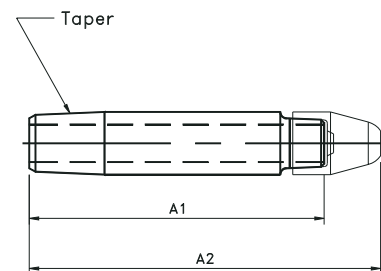

STRAIGHT FEMALE CAP SHANKS

5 RW Taper Code No. Alloy #130	Shank Length A1	Ass'y Length A2	Tip Offset O
OSF-2511-8	2-3/4	3-1/4	1/2
OSF-2511-12	2-3/4	3-1/4	3/4
OSF-2511-16	2-3/4	3-1/4	1
OSF-2513-8	3-1/4	3-3/4	1/2
OSF-2514-16	3-1/2	4	1
OSF-2515-20	3-3/4	4-1/4	1-1/4

4RW Taper (#1 MT)	5RW Taper (#2 MT)	Shank Length A1	Ass'y Length A2
CSF-246	CSF-256	1-1/2	2
CSF-248	CSF-258	2	2-1/2
CSF-2410	CSF-2510	2-1/2	3
CSF-2412	CSF-2512	3	3-1/2
CSF-2414	CSF-2514	3-1/2	4
CSF-2416	CSF-2516	4	4-1/2

FEMALE CAP TIPS AND SHANKS



SINGLE BEND TIPS

*WATER COOLING REACHES THE NOSE OF THE TIP, INCREASING LIFE OVER TRADITIONAL CAST OR FORGED OFFSET TIPS.
*WATER TUBES ARE SUPPLIED ON ALL DOUBLE BEND TIPS AND ON SEVERE SINGLE BEND TIPS. TIPS CAN BE SUPPLIED WITHOUT WATER TUBES ON REQUEST. THIS IS ONLY ADVISABLE IN VERY UNUSUAL APPLICATIONS.

NOTE: *Quantity shipped on specials may run +/- 10% of order quantity. (2 pieces on runs under 25 pieces)
*Six piece minimum order on special bends.

SINGLE BEND TIP CODING

S = SINGLE BEND TIP
16 = NOSE LENGTH IN 1/16" INCREMENTS
P = POINTED NOSE
D = DOME NOSE
F = FLAT NOSE
O = OFFSET NOSE
R = RADIUS NOSE*
1 = ALLOY SPECIFICATION (RWMA CLASS 1)
2 = ALLOY SPECIFICATION (RWMA CLASS 2)
3 = ALLOY SPECIFICATION (RWMA CLASS 3)
4 = TAPER SPECIFICATION (#4 RW TAPER)
5 = TAPER SPECIFICATION (#5 RW TAPER)
6 = TAPER SPECIFICATION (#6 RW TAPER)
7 = TAPER SPECIFICATION (#7 RW TAPER)
2 = LENGTH IN 1 INCH INCREMENTS
14 = FRACTIONAL LENGTH IN 1/16" INCREMENTS
8 = OFFSET IN 1/16" INCREMENTS
EXAMPLE: S16-P14214-8
*NOTE: Please specify radius

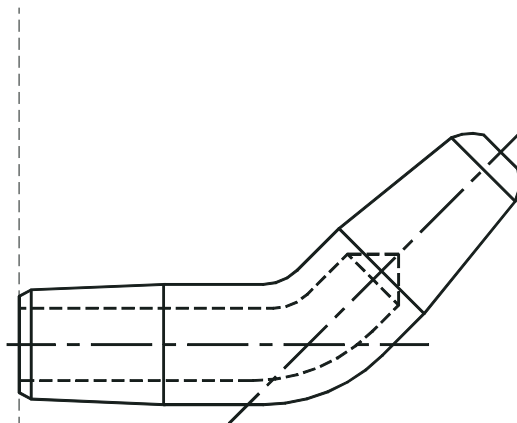
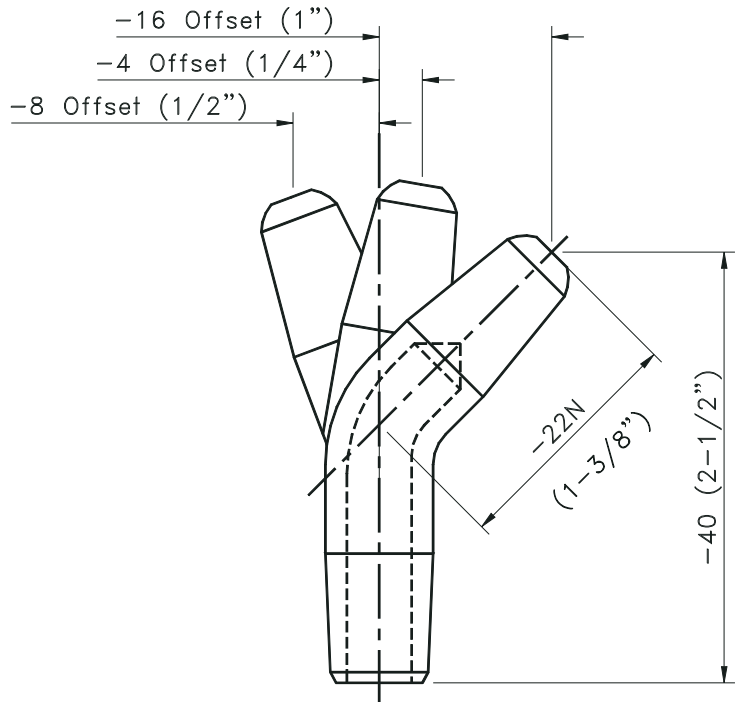

- 1/2"
- 1"
- 1-1/2"
- 2"
- 2-1/2"
- 3"
- 3-1/2"
- 4"
- 4-1/2"
- 5"
- 5-1/2"
- 6"

SINGLE BEND TIPS



DOUBLE BEND TIPS

Please call our order desk and ask about the many standard double and single bend tips in stock or determine your exact requirement using the coding shown below. You may also use the chart on this page to measure the nose, taper, overall length, and offset of the double bend tips you currently use.

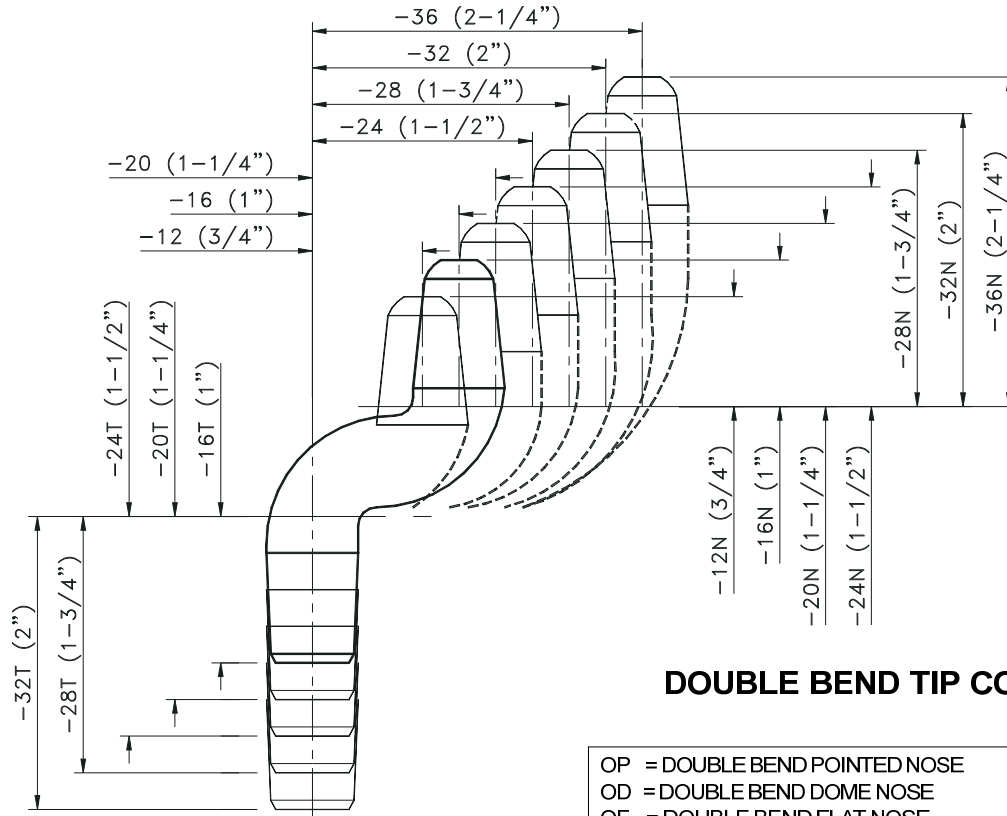

Minimum Overall Length = Nose Length + Taper Length + Body Diameter.
Maximum Offset = 2-1/2"

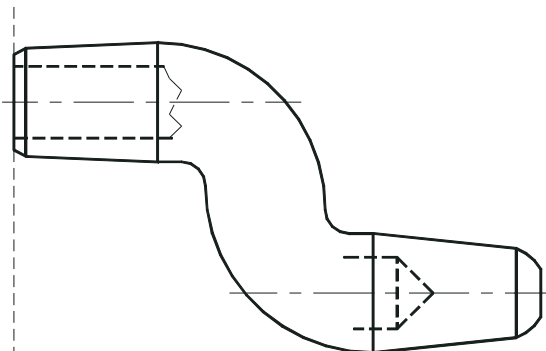

DOUBLE BEND TIP CODING

OP	= DOUBLE BEND POINTED NOSE
OD	= DOUBLE BEND DOME NOSE
OF	= DOUBLE BEND FLAT NOSE
OO	= DOUBLE BEND OFFSET NOSE
OR	= DOUBLE BEND RADIUS NOSE (SPECIFY RADIUS*)
1	= ALLOY SPECIFICATION (1 =RWMA CLASS 1)
2	= ALLOY SPECIFICATION (2 =RWMA CLASS 2)
3	= ALLOY SPECIFICATION (3 =RWMA CLASS 3)
4	= TAPER SPECIFICATION (4 =#4 RW TAPER)
5	= TAPER SPECIFICATION (5 =#5 RW TAPER)
6	= TAPER SPECIFICATION (6 =#6 RW TAPER)
7	= TAPER SPECIFICATION (7 =#7 RW TAPER)
3	= LENGTH IN 1 INCH INCREMENTS
14	= FRACTIONAL LENGTH IN 1/16" INCREMENTS
16	= OFFSET IN 1/16" INCREMENTS
20N	= NOSE LENGTH IN 1/16" INCREMENTS
24T	= TAPER LENGTH IN 1/16" INCREMENTS
EXAMPLE: OP-14314-16-20N-24T	
*FOR RADIUS NOSE, ADD THE REQUIRED RADIUS TO THE END OF THE PART NUMBER. (3=3" SPHERICAL RADIUS)	

DOUBLE BEND TIPS

- 1/2" -----
- 1" -----
- 1-1/2" -----
- 2" -----
- 2-1/2" -----
- 3" -----
- 3-1/2" -----
- 4" -----
- 4-1/2" -----
- 5" -----
- 5-1/2" -----
- 6" -----



SPOTWELD, INC.

Excellence in Resistance Welding

CAST IRREGULAR OFFSET TIPS

CAST IRREGULAR OFFSET TIPS

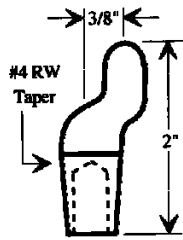

OF1-375

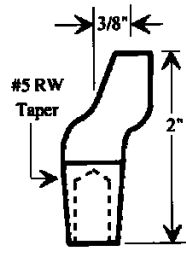

OF2-375

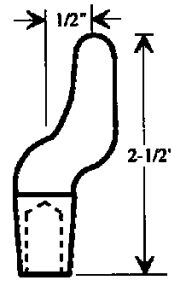

OF1-500S / OF2-500S
#4 RW / #5 RW

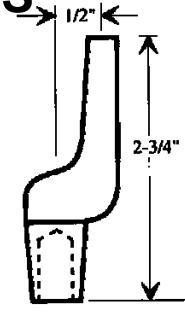

OF1-500 / OF2-500
#4 RW / #5 RW

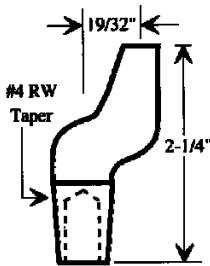

OF1-1932

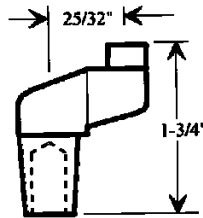

OF1-2532 / OF2-2532
#4 RW / #5 RW

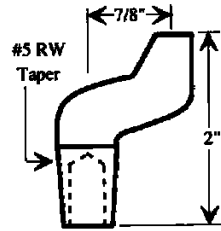

OF2-875

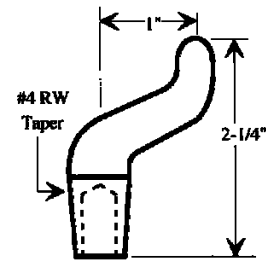

OF1-1000S

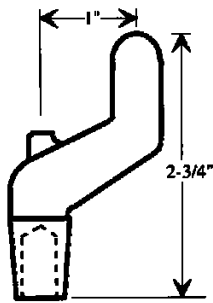

OF1-1000 / OF2-1000
#4 RW / #5 RW

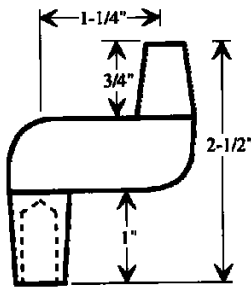

OF1-1250 / OF2-1250
#4 RW / #5 RW
(FORGED)

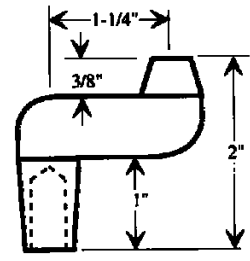

OF1-1250S / OF2-1250S
#4 RW / #5 RW
(FORGED)

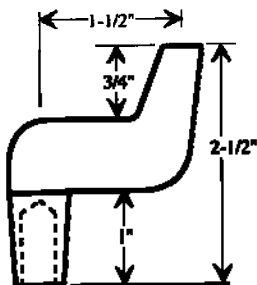

OF1-1500 / OF2-1500
#4 RW / #5 RW
(FORGED)

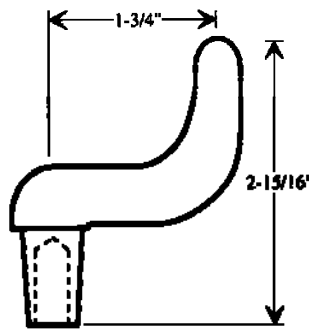

OF1-1750 / OF2-1750
(RW-985 / RW-999)
#4 RW / #5 RW

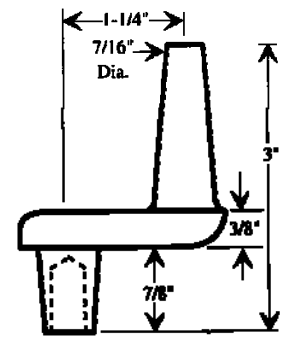

RW-969 / RW-1284
#4 RW / #5 RW



SPOTWELD, INC.

Excellence in Resistance Welding

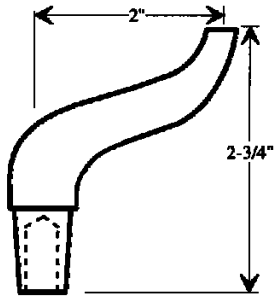

OF1-2000 / OF2-2000
(RW-1995 / RW-88)
#4 RW / #5 RW

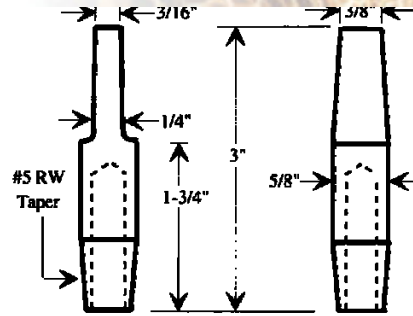

RW-990

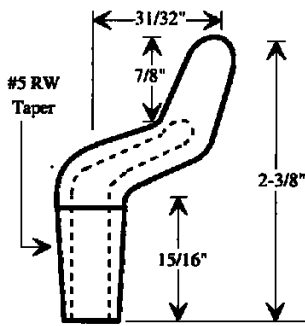

RW-1190
Cold Formed Tip

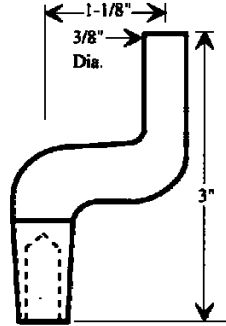

SPB-553-1 / SPB-553-2
(RW-1137 / RW-1138)
#4 RW / #5 RW
Cold Formed

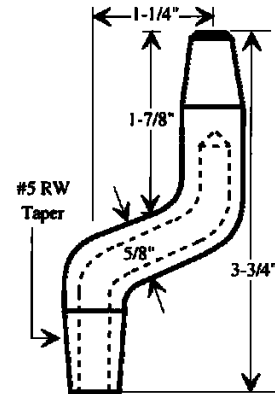

OF2-1250 3.75
Cold Formed
OP-25312-20-30N-16T

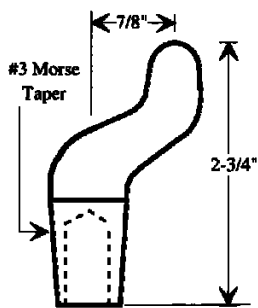

OF3-875

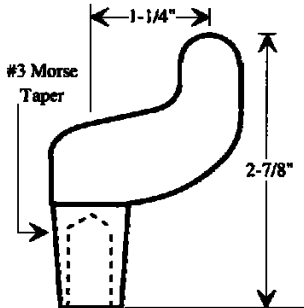

OF3-1250

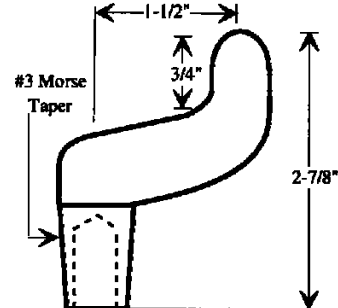

OF3-1500

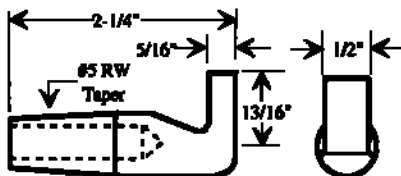

RW-1178

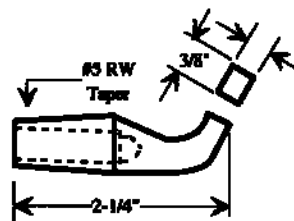

A2-200

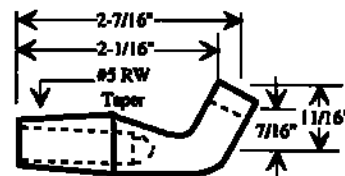

A2-205

CAST IRREGULAR OFFSET TIPS



RECTANGULAR & SQUARE FACE TIPS

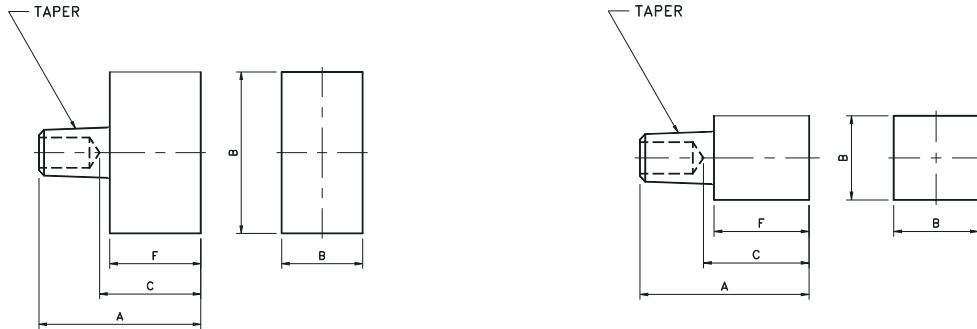

EXAMPLE OF PART CODING		
TS	=	TIPALLOY SQUARE/ RECTANGULAR FACE
2	=	RWMA CLASS 2 COPPER
5	=	#5 RW TAPER
24	=	LENGTH IN 1/16" (24 = 1-1/2")
10x16	=	WIDTH X LENGTH OF FACE IN 1/16" (10X16 = 5/8" X 1")
18	=	WATER HOLE DEPTH (IF DIFFERENT THAN STD. 7/8")
CT	=	COPPER TUNGSTEN FACING

RECTANGULAR FACE TIPS

Taper	#130 Code No.	Previous Code No.	Overall Length	Weld Face Dimension	Face to Water Hole	Length of Face
	Class 2		A	B	C	F

4 RW Taper (#1 MT)	TS-24-25-10X32	SP-220-1	1-9/16	5/8 x 2	13/16	11/16
	TS-24-26-8X16	SP-248-1	1-5/8	1/2 x 1		1
	TS-24-24-8X8	SP-261	1-1/2	1/2 x 1/2	1/2	7/8
	TS-24-24-8X16	SP-271-1	1-1/2	1/2 x 1		
	TS-24-35-4X16	SPB-329-1	2-3/16	1/4 x 1	1-5/16	

5 RW Taper (#2 MT)	TS-25-25-10X32	SP-220-2	1-9/16	5/8 x 2	13/16	11/16
	TS-25-29-10X16	SP-248-2	1-13/16	5/8 x 1	11/16	15/16
	TS-25-24-10X16	SP-271-2	1-1/2		1/2	5/8
	TS-25-28-10X10	SP-291	1-3/4	5/8 x 5/8	3/4	7/8
	TS-25-35-4X16	SPB-329-2	2-3/16	1/4 x 1	1-5/16	1

* Additional rectangular or square face sizes and lengths available.



SPOTWELD, INC.

Excellence in Resistance Welding

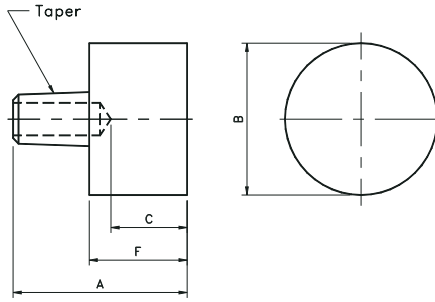

EXAMPLE OF PART CODING:	
TR =	TIPALLOY ROUND FACE TIP
2 =	CLASS 2 COPPER
5 =	#5 RW TAPER
24 =	OVERALL LENGTH IN 1/16"
14 =	WELD FACE DIAMETER IN 1/16"
16 =	WATER HOLE DEPTH IN 1/16" IF DIFFERENT THAN STANDARD (7/8")
CT =	COPPER TUNGSTEN FACING

ROUND FACE TIPS

New Part No.	Old Part No.	Overall Length	Weld Face	Face to Water Dia.	Length of Face Hole
		A	B	C	F
4 RW Taper (#1 MT)					
TR-24-24-14	SP-221-1	1-1/2	7/8	5/8	7/8
TR-24-20-16-13	SP-222	1-1/4	1	7/16	5/8
TR-24-20-12-16	SPB-680-1	1-1/4	3/4	1/4	5/8
TR-24-20-20-16	SPB-682-1	1-1/4	1-1/4	1/4	5/8
TR-24-32-14-20	SP-279	2	7/8	3/4	1-3/8
5 RW Taper (#2 MT)					
TR-25-24-14-14	SP-221-2	1-1/2	7/8	5/8	5/8
TR-25-24-16-18	SP-223	1-1/2	1	3/8	1
TR-25-30-14-14	SP-250	1-7/8	7/8	1	1
TR-25-24-14-18	SP-292-2	1-1/2	7/8	3/8	5/8
TR-25-24-12-18	SPB-681-2	1-1/2	3/4	3/8	5/8
TR-25-24-20-18	SPB-682-2	1-1/2	1-1/4	3/8	5/8
TR-25-46-12-14	SP-275	2-7/8	3/4	2	2
TR-25-46-16-14	SP-276	2-7/8	1	2	2
TR-25-32-16-20	SP-280	2	1	3/4	1-1/8
TR-25-32-24-16	SPB-510-2	2	1-1/2	1	1-1/8

* Additional diameters and lengths available from stock.

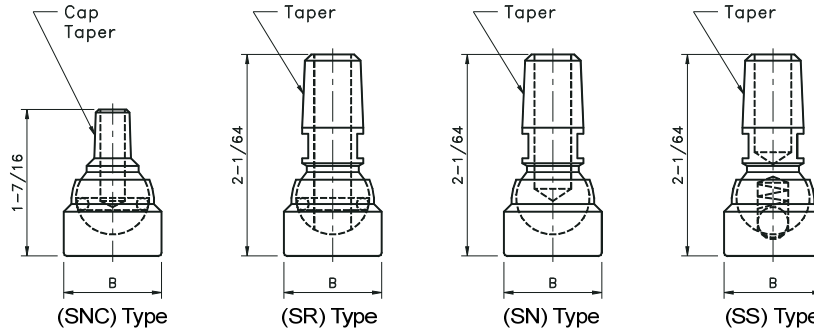

SWIVEL TIPS

5 RW Male Cap Taper Part No.	Spring Ball Type Part No.	Blind Hole Type Part No.	O Ring Type Part No.	Weld Face Diameter B
	Part No.	Part No.	Part No.	
4 RW Taper (#1 MT)				
-	SS-147	SN-147	SR-147	7/8
-	SS-148	SN-148	SR-148	1
-	SS-1410	SN-1410	SR-1410	1-1/4
-	SS-1412	SN-1412	SR-1412	1-1/2
5 RW Taper (#2 MT)				
SNC-157	SS-157	SN-157	SR-157	7/8
SNC-158	SS-158	SN-158	SR-158	1
SNC-1510	SS-1510	SN-1510	SR-1510	1-1/4
-	SS-1512	SN-1512	SR-1512	1-1/2

EXAMPLE OF PART CODING:	
SNC =	SWIVEL - MALE CAP TAPER
SS =	SWIVEL - SPRING AND BALL TYPE
SNC =	SWIVEL - BLIND HOLE TYPE
SR =	SWIVEL - "O" RING TYPE
1 =	CLASS 2 COPPER
4 =	#4 RW TAPER
7 =	WELD FACE DIAMETER IN 1/8"

SWIVEL & ROUND FACE TIPS



STUD & NUT ELECTRODES

STUD & NUT ELECTRODES

T-600 SERIES

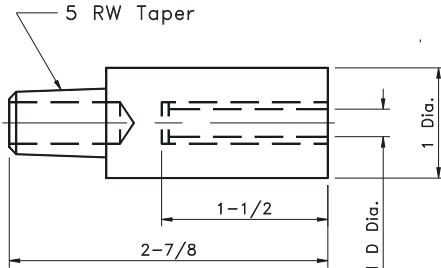

T-600-CT SERIES

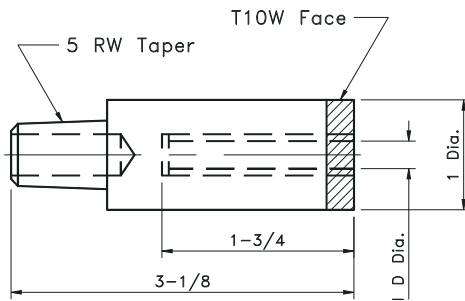

T-610 SERIES

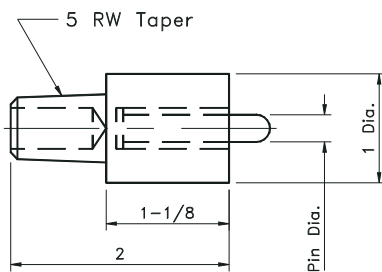

T-610-CT SERIES

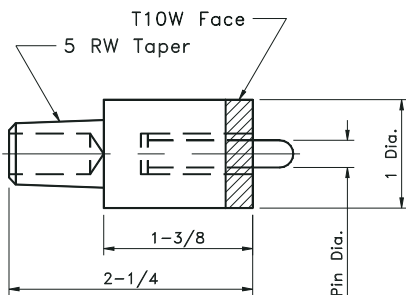

UPPER ELECTRODE - CT FACED

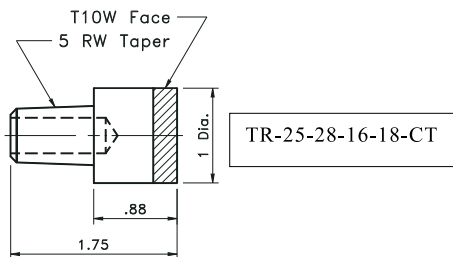

STUD ELECTRODES - 5RW TAPER

PART #	PART #	PART #	STUD SIZE & DIA.	
ALLOY #130	ALLOY #130 WITH T-10W FACE	ALLOY #200		
T-601	T-601-CT	T-701	#8	.164 DIA.
T-602	T-602-CT	T-702	#10	.190 DIA.
T-603	T-603-CT	T-703	#12	.216 DIA.
T-604	T-604-CT	T-704	1/4	.250 DIA.
T-605	T-605-CT	T-705	5/16	.312 DIA.
T-606	T-606-CT	T-706	3/8	.164 DIA.
T-607	T-607-CT	T-707	7/16	.164 DIA.

METRIC STUD ELECTRODES - 5RW TAPER

PART #	PART #	PART #	STUD SIZE & DIA.	
ALLOY #130	ALLOY #130 WITH T-10W FACE	ALLOY #200		
T-606MM	T-606MM-CT	T-706MM	6MM	.236 DIA.
T-608MM	T-608MM-CT	T-708MM	8MM	.316 DIA.
T-6010MM	T-6010MM-CT	T-7010MM	10MM	.394 DIA.

SELF PILOTING NUT ELECTRODES - 5RW TAPER

PART #	PART #	PART #	NUT SIZE	PIN DIA	PILOT PIN HEIGHT
ALLOY #130	ALLOY #130 WITH T-10W FACE	ALLOY #200			
T-611	T-611-CT	T-711	#8-32	.126 DIA.	3/16
T-612	T-612-CT	T-712	#10-24	.144 DIA.	3/16
T-613	T-613-CT	T-713	#12-24	.170 DIA.	1/4
T-614	T-614-CT	T-714	1/4-20	.187 DIA.	5/16
T-615	T-615-CT	T-715	5/16-18	.250 DIA.	5/16
T-616	T-616-CT	T-716	3/8-16	.312 DIA.	3/8
T-617	T-617-CT	T-717	7/16-14	.355 DIA.	3/8
T-618	T-618-CT	T-718	1/2-13	.414 DIA.	3/8

METRIC NUT ELECTRODES - 5RW TAPER

PART #	PART #	PART #	STUD SIZE & DIA.	
ALLOY #130	ALLOY #130 WITH T-10W FACE	ALLOY #200		
T-616MM	T-616MM-CT	T-716MM	6MM	.188 DIA.
T-618MM	T-618MM-CT	T-718MM	8MM	.260 DIA.
T-6110MM	T-6110MM-CT	T-7110MM	10MM	.328 DIA.

Stepped pins are also available, please supply us with a print, sample or consult factory.

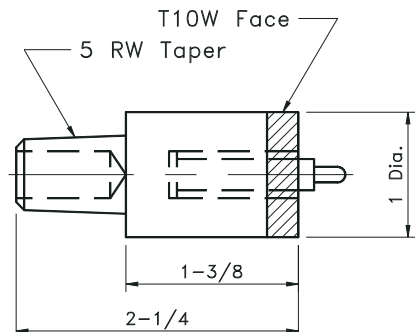



STUD & NUT ELECTRODES

STUD ELECTRODES - SPECIAL 7RW TAPER			
PART # ALLOY #130	PART # ALLOY #130 WITH T-10W FACE	STUD SIZE & DIA.	
T-201	T-201-CT	#8	.164 DIA.
T-202	T-202-CT	#10	.190 DIA.
T-203	T-203-CT	#12	.216 DIA.
T-204	T-204-CT	1/4	.250 DIA.
T-205	T-205-CT	5/16	.312 DIA.
T-206	T-206-CT	3/8	.164 DIA.
T-207	T-207-CT	7/16	.164 DIA.

Also available in metric sizes.

SELF PILOTING NUT ELECTRODES - SPECIAL 7RW TAPER				
PART # ALLOY #130	PART # ALLOY #130 WITH T-10W FACE	NUT SIZE	PIN DIA	PILOT PIN HEIGHT
T-211	T-211-CT	#8-32	.126 DIA.	3/16
T-212	T-212-CT	#10-24	.144 DIA.	3/16
T-213	T-213-CT	#12-24	.170 DIA.	1/4
T-214	T-214-CT	1/4-20	.187 DIA.	5/16
T-215	T-215-CT	5/16-18	.250 DIA.	5/16
T-216	T-216-CT	3/8-16	.312 DIA.	3/8
T-217	T-217-CT	7/16-14	.355 DIA.	3/8
T-218	T-218-CT	1/2-13	.414 DIA.	3/8

STUD ELECTRODES - 5RW TAPER		
PART # ALLOY #130	PART # ALLOY #130 WITH T-10W FACE	STUD SIZE & DIA.
T-501	T-501-CT	#8 .164 DIA.
T-502	T-502-CT	#10 .190 DIA.
T-503	T-503-CT	#12 .216 DIA.
T-504	T-504-CT	1/4 .250 DIA.

SELF PILOTING NUT ELECTRODES - 5RW TAPER				
PART # ALLOY #130	PART # ALLOY #130 WITH T-10W FACE	NUT SIZE	PIN DIA	PILOT PIN HEIGHT
T-511	T-511-CT	#8-32	.126 DIA.	3/16
T-512	T-512-CT	#10-24	.144 DIA.	3/16
T-513	T-513-CT	#12-24	.170 DIA.	1/4

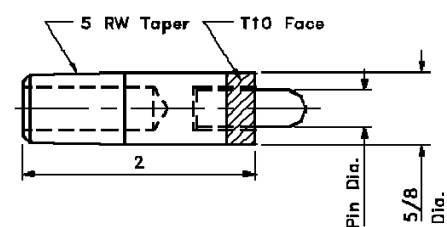
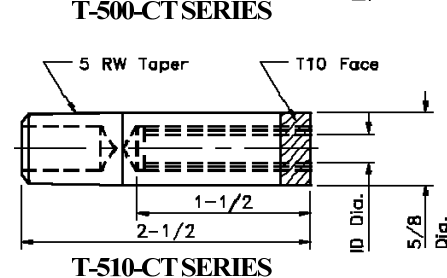
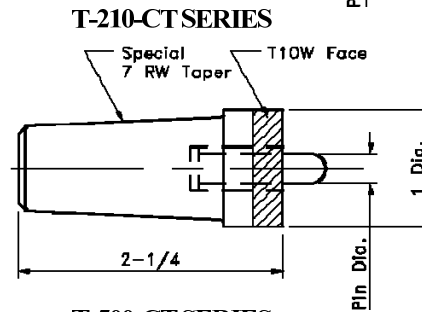
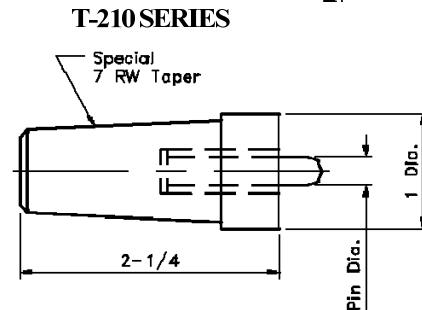
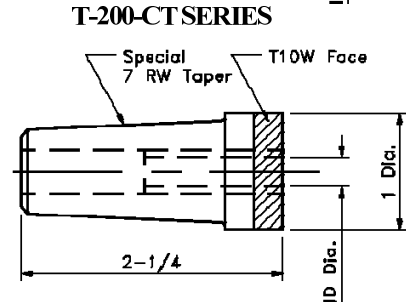
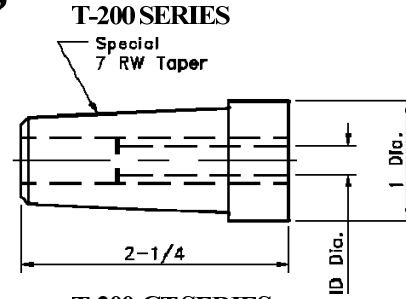

STUD & NUT ELECTRODES



BUILD A DIE COMPONENTS



ELECTRODES	
PART #	DIA.
TDTE-2-19-BLANK	3/4"
TDTE-2-22-BLANK	7/8"
TDTE-2-25-BLANK	1"
TDTE-2-32-BLANK	1-1/4"

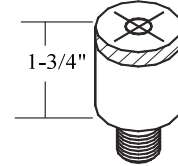
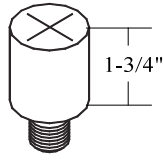

FIXED PIN NUT ELECTRODES		
PART #	NUT SIZE	DIA.
TDTN-2-25-611	#8	1"
TDTN-2-25-612	#10	1"
TDTN-2-25-613	#12	1"
TDTN-2-25-614	1/4"	1"
TDTN-2-25-615	5/16"	1"
TDTN-2-25-616	3/8"	1"
TDTN-2-25-617	7/16"	1"
TDTN-2-25-618	1/2"	1"
TDTN-2-25-614MM	4MM	1"
TDTN-2-25-616MM	6MM	1"
TDTN-2-25-618MM	8MM	1"
TDTN-2-25-6110MM	10MM	1"
TDTN-2-25-6112MM	12MM	1"

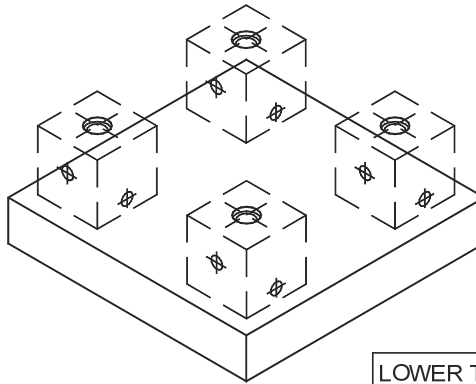
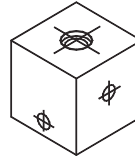
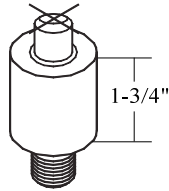

STUD ELECTRODES		
PART #	NUT SIZE	DIA.
TDTS-2-25-601	#8	1"
TDTS-2-25-602	#10	1"
TDTS-2-25-603	#12	1"
TDTS-2-25-604	1/4"	1"
TDTS-2-25-605	5/16"	1"
TDTS-2-25-606	3/8"	1"
TDTS-2-25-607	7/16"	1"
TDTS-2-25-608	1/2"	1"
TDTS-2-25-604MM	4MM	1"
TDTS-2-25-606MM	6MM	1"
TDTS-2-25-608MM	8MM	1"
TDTS-2-25-6110MM	10MM	1"
TDTS-2-25-6112MM	12MM	1"

NOTE: For copper tungsten faced electrodes please add a "-CT" to the end of the part number.

NOTE: For copper tungsten faced electrodes please add a "-CT" to the end of the part number.

WATER COOLED BLOCKS		
PART #	STOCK SIZE	THD.
T-4000-01	2" X 2"	5/8-11

LOWER THREADED BODY			
PART #	THD. SIZE	DIA.	USE HEAD
TDT-25-C	5/8-11	1"	TCN-M04 - M09
TDT-30-C	5/8-11	1-1/4"	TCN-M10 - M13
TDT-25-C-CL	5/8-11	1"	TCL-200 SERIES
TDT-30-C-CL	5/8-11	1-1/4"	TCL-300 SERIES

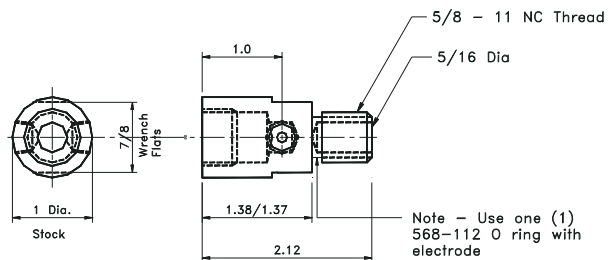
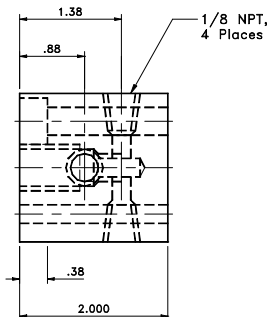
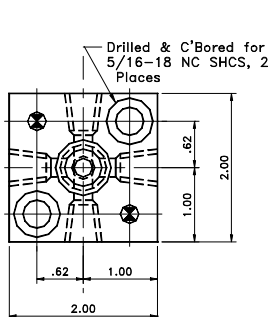

Note - Use with TDT-25/30-C for welding fixtures and dies.

BUILD A DIE



SPOTWELD, INC.

Excellence in Resistance Welding

AIR PRESSURE NUT ELECTRODES

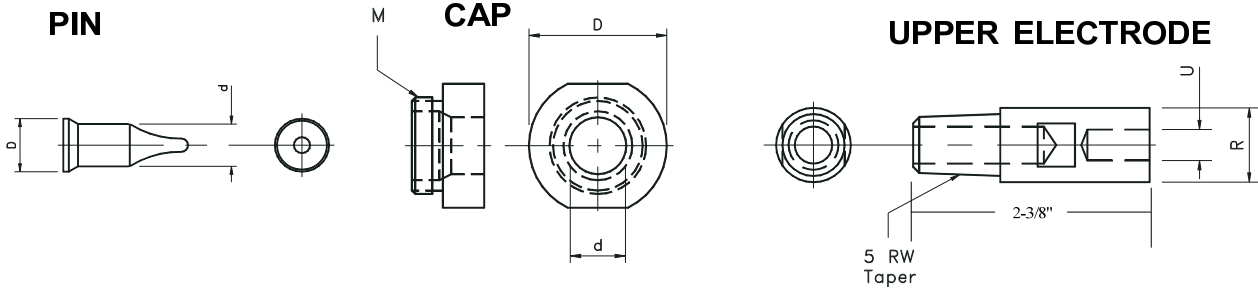

PIN			CAP				UPPER ELECTRODE		NUT	
NUMBER	d	D	NUMBER	D	d	M	ELECTRODE	SIZE	R	U
TDP-M04	5	12	TCN-M04	25	5	18	TNFD-16-M5-16-3	M 4-6	16MM	5MM
TDP-M05	6	12	TCN-M05	25	6	18	TNFD-16-M5-16-3	M 4-6	16MM	5MM
TDP-M06	7	12	TCN-M06	25	7	18	TNFD-20-M6-16-3	M 6-7	20MM	6MM
TDP-M07	8	12	TCN-M07	25	8	18	TNFD-20-M6-16-3	M 6-7	20MM	6MM
TDP-M08	9	12	TCN-M08	25	9	18	TNFD-20-M8-16-3	M 8-9	20MM	7.5MM
TDP-M09	10	12	TCN-M09	25	10	18	TNFD-20-M8-16-3	M 8-9	20MM	7.5MM
TDP-M10	11	16	TCN-M10	32	11	22	TNFD-20-M10-16-3	M 10-11	20MM	10MM
TDP-M11	12	16	TCN-M11	32	12	22	TNFD-20-M10-16-3	M 10-11	20MM	10MM
TDP-M12	13	16	TCN-M12	32	13	22	TNFD-20-M12-16-3	M 12-13	20MM	12MM
TDP-M13	14	16	TCN-M13	32	14	22	TNFD-20-M12-16-3	M 12-13	20MM	12MM

NOTE: For solid copper tungsten heads please add a "-CT" to the end of the part number.

NOTE: For copper tungsten faced electrodes please add a "-CT" to the end of the part number.

BODY NUMBER	D	TAPER / THREAD	CAP THREAD
TDH-25-A	25	MT #1	18MM
TDH-25-B	25	1/10	18MM
TDH-25-C	25	MT #2	18MM
TDH-25-D	25	1/10	18MM
TDH-25-E	25	1/5	18MM
TDH-30-A	32	MT #2	22MM
TDH-30-B	32	1/10	22MM
TDT-25-C	25	5/8-11	18MM
TDT-30-C	32	5/8-11	22MM
TDT-25-C-CL	25	5/8-11	5/8-18
TDT-30-A-CL	32	5/8-11	7/8-14

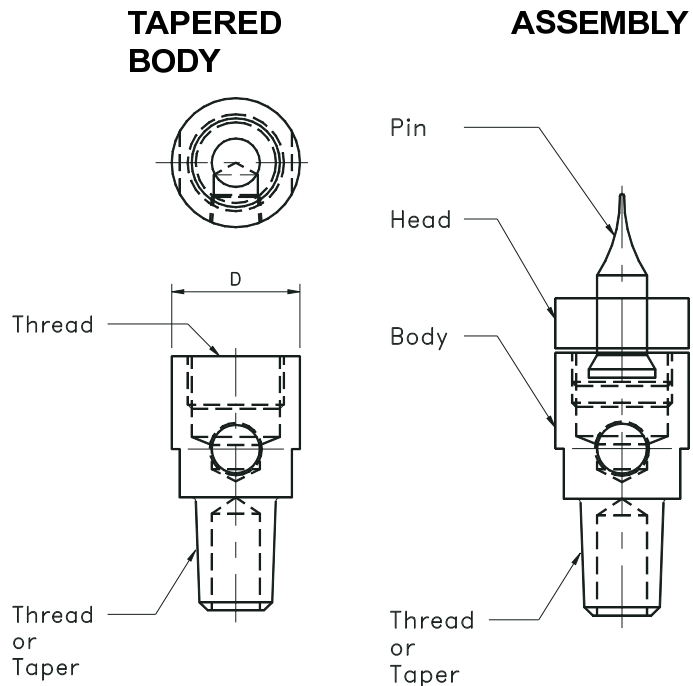

Specials available upon request.

AIR PRESSURE NUT ELECTRODES



TCL HEADS & COMPONENTS

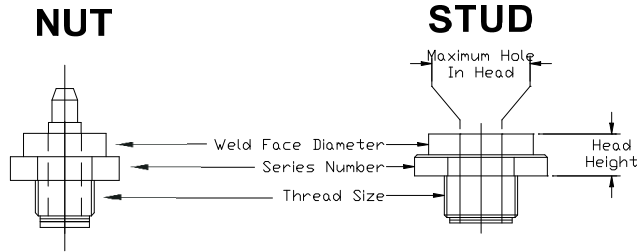

SERIES	THREAD SIZE	WELD FACE DIA.	HEAD HEIGHT	MAX. HOLE DIA.
TCL-201	5/8-18"	7/8"	1/2"	.427 (10.85) ID
TCL-301	7/8-14"	1-1/4"	1/2"	.642 (16.31) ID
TCL-401	1-1/8-12"	1-1/2"	5/8"	.852 (21.64) ID

*specials available in round stock or hex stock

WELD NUT PIN NOSE STYLES

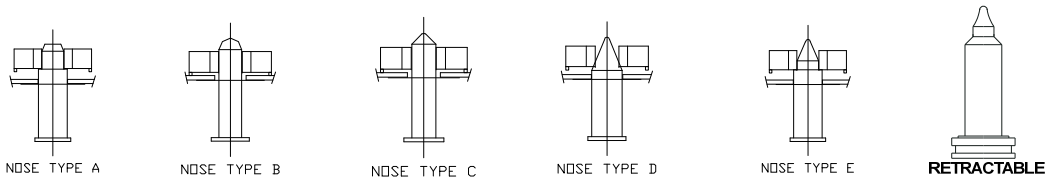

STANDARD BODY & MOUNTING STYLES

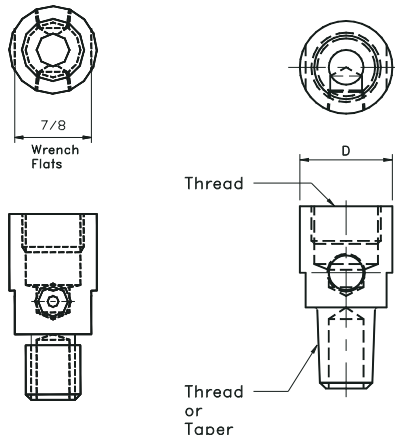
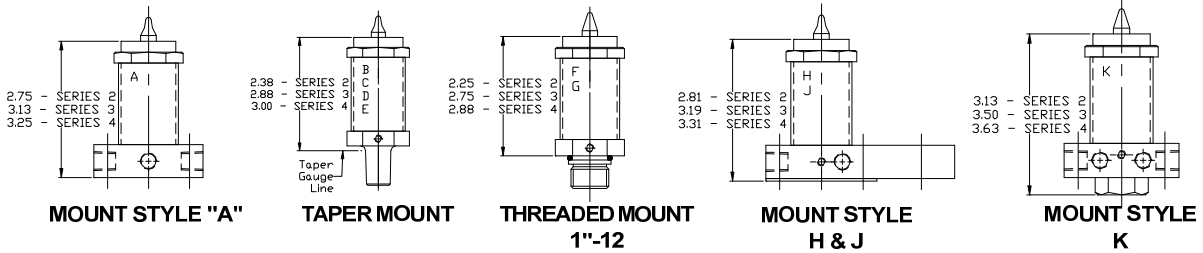

INFORMATION REQUIRED TO ORDER "TCL" PARTS	TCL HEAD	TCL PIN	STUD
Nut type (piloted, Non-oiloted, ect)		X	
Nut style(sq., hex, round)		X	
Head Series		X	X
Hole in stamping	X	X	X
Hole in nut	X	X	X
Stamping thickness	X	X	
Hand load		X	
Auto load		X	
Air / Spring operated		X	
Retractable (Air only)		X	
Length of stud	X		X
Head dia. Of stud	X		X
Stud dia	X		X

CONSULT FACTORY FOR ADDITIONAL INFORMATION ON THESE ITEMS



TIP ADAPTERS

TIP ADAPTERS

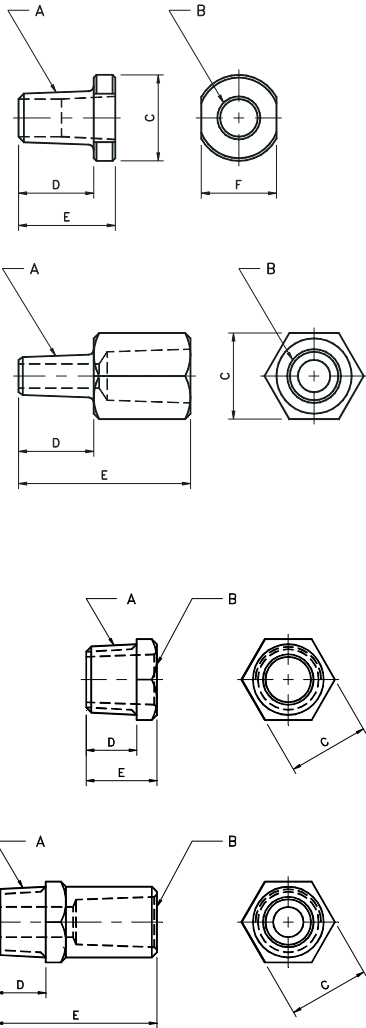

EXAMPLE OF PART CODING:

AT	=	TAPER
H	=	HEX STOCK
R	=	ROUND STOCK
2	=	CLASS 2 COPPER
4	=	# 4 RW FEMALE TAPER
5	=	# 5 RW MALE TAPER
8	=	LENGTH IN 1/8" INCREMENTS

FEMALE TAPER TO MALE TAPER

#130 Code No.	Male Taper A	Female Taper B	Stock Size C	Length Under Head D	Overall Length E	Wrench Flats F
AT-R245-9	5 RW	4 RW	1	7/8	1-1/8	7/8
AT-R247-12	7 RW	5 RW	1-1/8	1-1/4	1-1/2	1
AT-R257-12						

#130

Code No.	Male Taper A	Female Taper B	Stock Size C	Length Under Head D	Overall Length E
AT-H254-15	4 RW	5 RW	1	7/8	1-7/8

FEMALE TAPER TO MALE STRAIGHT THREAD

#130 Code No.	Male Thread A	Female Taper B	Stock Size C	Length Under Head D	Overall Length Head E	
AS-H245-7	5/8-18	4 RW	1	5/8	7/8	
AS-H255-13		5 RW			1-5/8	
AS-H247-7	7/8-14	4 RW			1-1/4	7/8
AS-H257-7		5 RW				
AS-H248-7	1-14	4 RW				
AS-H258-7		5 RW				

* Sealing Ring included on Straight Threaded Adapters

COPPER SEALING RINGS

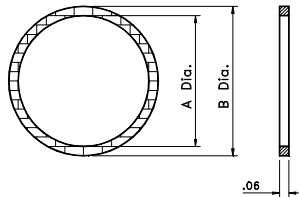

Part Number	A Dia.	B Dia.
760-0-0001	7/8 Dia.	1 Dia.
780-0-0001	1 Dia.	1-1/8 Dia.

EXAMPLE OF PART CODING:

AS	=	STRAIGHT THREAD
H	=	HEX STOCK
R	=	ROUND STOCK
2	=	CLASS 2 COPPER
4	=	#4 RW FEMALE TAPER
7	=	EXTERNAL THREAD SIZE
8	=	LENGTH IN 1/8" INCREMENTS



TIP ADAPTERS

FEMALE TAPER TO MALE PIPE THREAD					
#130 Code No.	Male Pipe Thread	Female Taper	Stock Size	Length Under Head	Overall Length
	A	B	C	D	E
AP-H24A-8 *	3/8			3/4	1
AP-H24B-7 *					7/8
AP-H24B-8					1
AP-H24B-10	1/2	4 RW	1	5/8	1-1/4
AP-H24B-12					1-1/2
AP-H24B-16					2
AP-H24B-20					2-1/2
AP-H24B-24					3
AP-H24C-7 *	5/8				7/8
AP-H24C-8					1
AP-H25A-13	3/8			3/4	1-5/8
AP-H25B-7 *					7/8
AP-H25B-8					1
AP-H25B-10	1/2	5 RW	1	5/8	1-1/4
AP-H25B-12					1-1/2
AP-H25B-16					2
AP-H25B-20					2-1/2
AP-H25B-24					3
AP-H25C-7 *	5/8				7/8
AP-H25C-8					1

EXAMPLE OF PART CODING:		
AP	=	PIPE THREAD
H	=	HEX STOCK
R	=	ROUND STOCK
2	=	CLASS 2 COPPER
4	=	#4 RW TAPER
A	=	3/8" MALE PIPE THREAD
B	=	1/2" MALE PIPE THREAD
C	=	5/8" MALE PIPE THREAD
D	=	3/4" MALE PIPE THREAD
8	=	LENGTH IN 1/8" INCREMENTS

#130 Code No.	Male Pipe Thread	Female Taper	Stock Size	Length Under Head	Overall Length
	A	B	C	D	E
AP-H35D-11*					1-3/8
AP-H35D-12					1-1/2
AP-H35D-16		5 RW			2
AP-H35D-20					2-1/2
AP-H35D-24	3/4		1-1/4	7/8	3
AP-H36D-11*					1-3/8
AP-H36D-12					1-1/2
AP-H36D-16		6 RW			2
AP-H36D-20					2-1/2
AP-H36D-24					3

* Denotes Minimum Length Available

TAPER ADAPTER

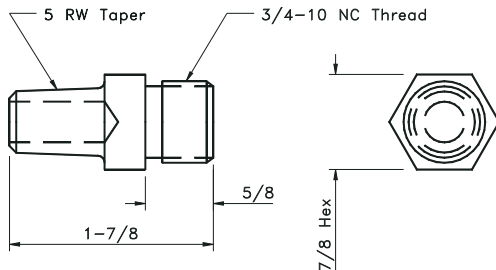

810408-A

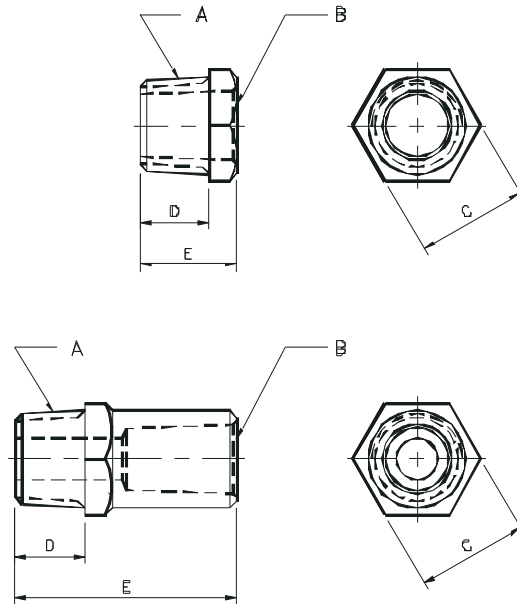

TIP ADAPTERS



WELDER ARMS

EXAMPLE OF PART CODING:

- TWA = TIPALLOY WELDER ARM
- A = ARM DIAMETER IN 1/8" INCREMENTS
- B = LENGTH TO CENTERLINE OF SHANK HOLE IN 1/4" INCREMENTS
- C = SHANK HOLE DIAMETER IN 1/8" INCREMENTS

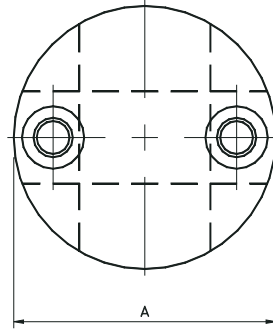

TIPALLOY WELDING MACHINE ARMS

PART #	DIA.	O.A.L.	HOLE DIA.
	A	B	C
TWA-16-48-8	2"	12	1"
TWA-16-64-8		16	
TWA-16-72-8		18	
TWA-16-80-8		20	
TWA-16-96-8		24	
TWA-16-144-8		36	
TWA-20-48-10	2-1/2"	12	1-1/4"
TWA-20-64-10		16	
TWA-20-72-10		18	
TWA-20-80-10		20	
TWA-20-96-10		24	
TWA-20-144-10		36	
TWA-24-48-12	3"	12	1-1/2"
TWA-24-64-12		16	
TWA-24-72-12		18	
TWA-24-80-12		20	
TWA-24-96-12		24	
TWA-24-144-12		36	

OTHER LENGTHS AND DIAMETERS AVAILABLE.

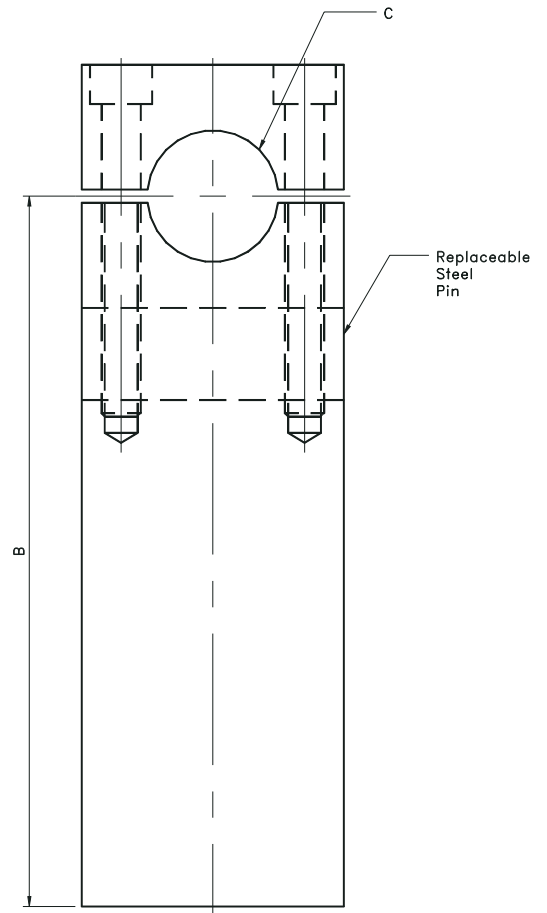

WELDER ARMS



HOLDER AND ADAPTER COMBINATIONS

The following illustrations are a representative sampling of ways to use Tipaloy Welder Arms, Holders, "T" Connectors, and Adapters. There are many other possible combinations. The following pages can identify components to suit your individual applications.

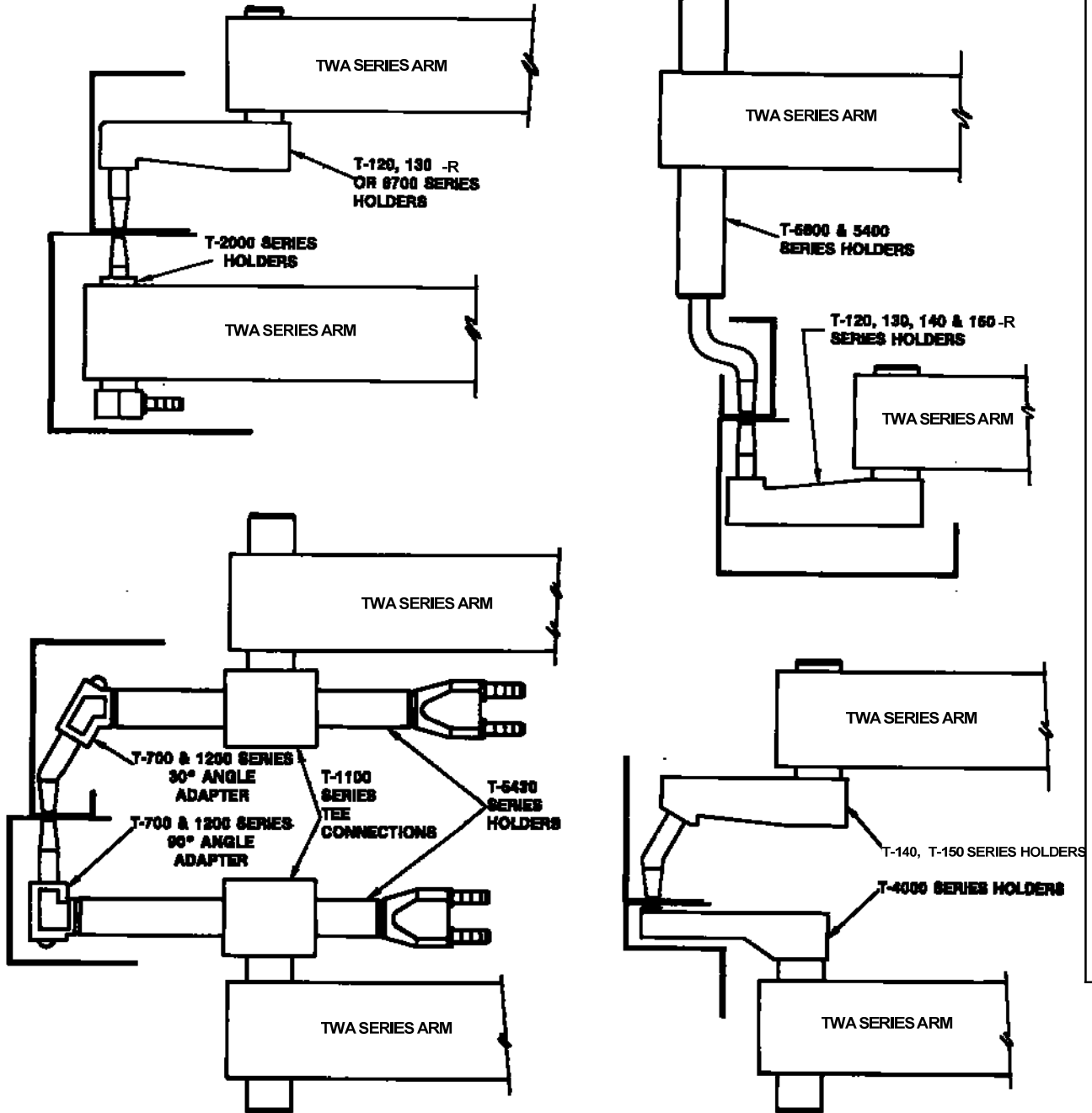

HOLDER AND ADAPTER COMBINATIONS



PLATEN ADAPTERS

Tipaloy platen adapters make it possible to use press type welders for a wider range of applications, including stud and nut welding, single spot welding, and special fixture components. Both sizes match RWMA T-slot spacing.

T-8000 SERIES

Use T-8000 series for 3-1/2" centerline

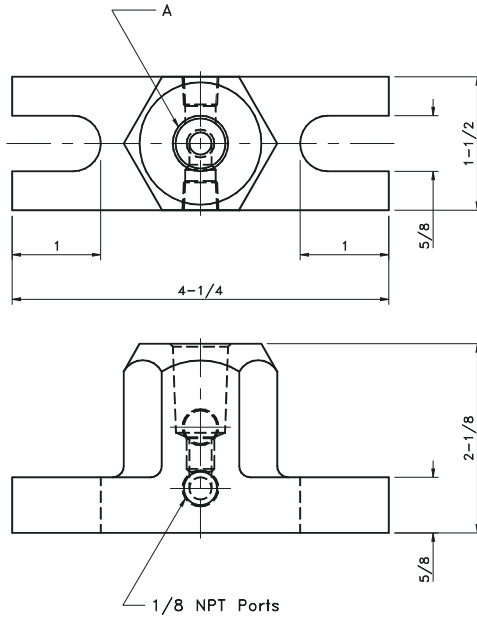

Part Number	Taper or Thread Size A
T-8001	4 RW (#1 MT)
T-8002	5 RW (#2 MT)
T-8003	6 RW -
T-8004	7 RW (#3 MT)
T-8005	SPECIAL 7RW
T-8006	1/2" NPT
T-8007	5/8" NPT
T-8008	3/4" NPT
T-8009	7/8-14 NPT
T-8010	1-14 NPT
T-8012	7/8-9 NC
T-8013	5/8-11 NC
T-8014	3/4-10 NC

T-8100 SERIES

Use T-8100 series for 5" - 6" centerline

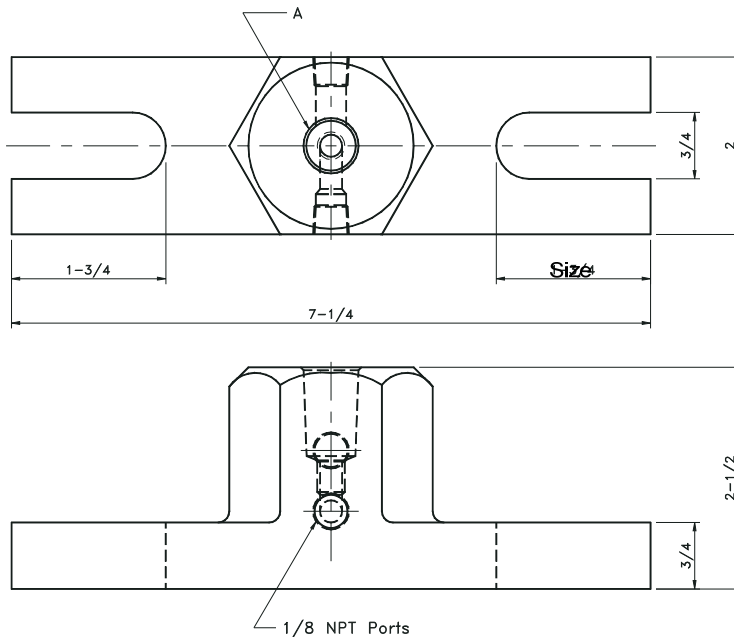

Part Number	Taper or Thread A
T-8102	5 RW (#2 MT)
T-8103	6 RW -
T-8104	7 RW (#3 MT)
T-8105	SPECIAL 7RW
T-8106	1/2" NPT
T-8107	5/8" NPT
T-8108	3/4" NPT
T-8109	7/8-14 NPT
T-8110	1-14 NPT
T-8111	T-230SERIES
T-8112	7/8-9 NC
T-8113	5/8-11 NC
T-8114	3/4-10 NC

PLATEN ADAPTERS



STANDARD T-5400 STRAIGHT HOLDERS NON-EJECTOR TYPE

	Part Number	Holder Body Diameter	Body Length
		A	B
4 RW Taper (#1 MT)	T-5400 **	3/4	8"
	T-5401	7/8	
	T-5402 *	1	
	T-5403	1-1/4	
	T-5404	1-1/2	
5 RW Taper (#2 MT)	T-5405	7/8	8"
	T-5406 *	1	
	T-5407 *	1-1/4	
	T-5408 *	1-1/2	
7 RW Taper (#3 MT)	T-5409	1-1/4	8"
	T-5410 *	1-1/2	

ALSO AVAILABLE IN THREADED STYLE

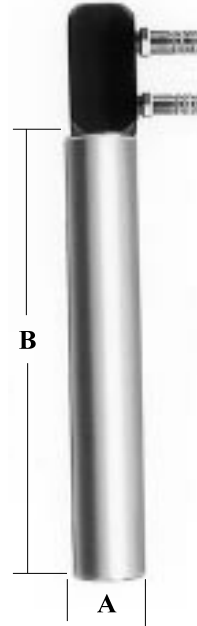

STANDARD T-5600 STRAIGHT HOLDERS EJECTOR TYPE

	Part Number	Holder Body Diameter	Body Length
		A	B
4 RW Taper (#1 MT)	T-5600 **	3/4	8"
	T-5601	7/8	
	T-5602 *	1	
	T-5603	1-1/4	
	T-5604	1-1/2	
5 RW Taper (#2 MT)	T-5605	7/8	8"
	T-5606 *	1	
	T-5607 *	1-1/4	
	T-5608 *	1-1/2	
7 RW (#3 MT)	T-5609	1-1/4	8"
	T-5610 *	1-1/2	
8 Degree Taper .625 Eng.	T-5611	1	8"
	T-5612	1-1/4	
	T-5613	1-1/2	
8 Degree Taper .875 Eng.	T-5614	1-1/4	8"
	T-5615	1-1/2	

* ALSO STOCKED IN 12" BARREL LENGTHS

** EXTERNAL THREAD ON BARREL AT HOLDER HEAD

SPECIAL LENGTHS AVAILABLE

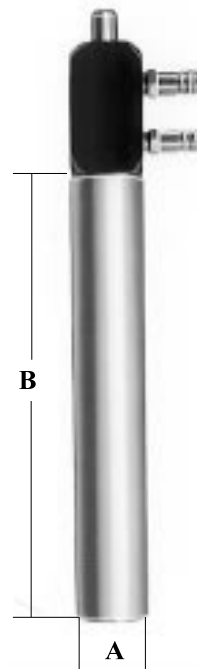

STRAIGHT TAPERED BARREL HOLDERS



SPOTWELD, INC.

Excellence in Resistance Welding



CLOSE COUPLED HOLDERS T-2000/T-2000E

	Part Number Non-Ejector Type	Part Number Ejector Type	Holder Body Diameter	Holder Body Length
4 RW Taper (#1 MT)	T-2000	T-2000-E	3/4	3
	T-2001	T-2001-E	7/8	
	T-2002	T-2002-E	1	
5 RW Taper (#2 MT)	T-2003	T-2003-E	1	3
	T-2004	T-2004-E	1-1/4	
	T-2005	T-2005-E	1-1/2	

Custom barrel lengths available

SPECIAL HOLDERS



SPECIAL 20 DEGREE OFFSET HOLDERS

Part Number	Shank Dia.
T-5200	1
T-5205	1-1/4

5 RW Taper
(#2 MT)

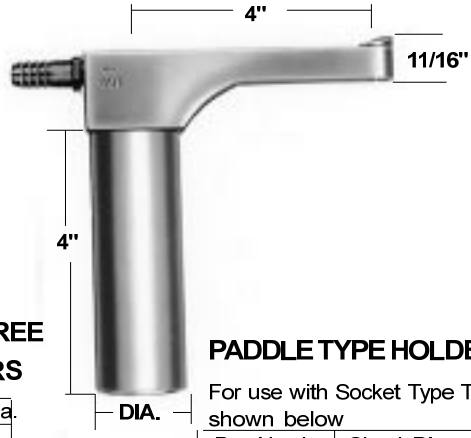

PADDLE TYPE HOLDERS

For use with Socket Type Tips as shown below

Part Number	Shank Diameter
T-4012	3/4
T-4014	7/8
T-4016	1
T-4020	1-1/4
T-4024	1-1/2

Replacement Screw P/N 10F37SHC

SOCKET TIPS FOR USE WITH T-4000 HOLDERS

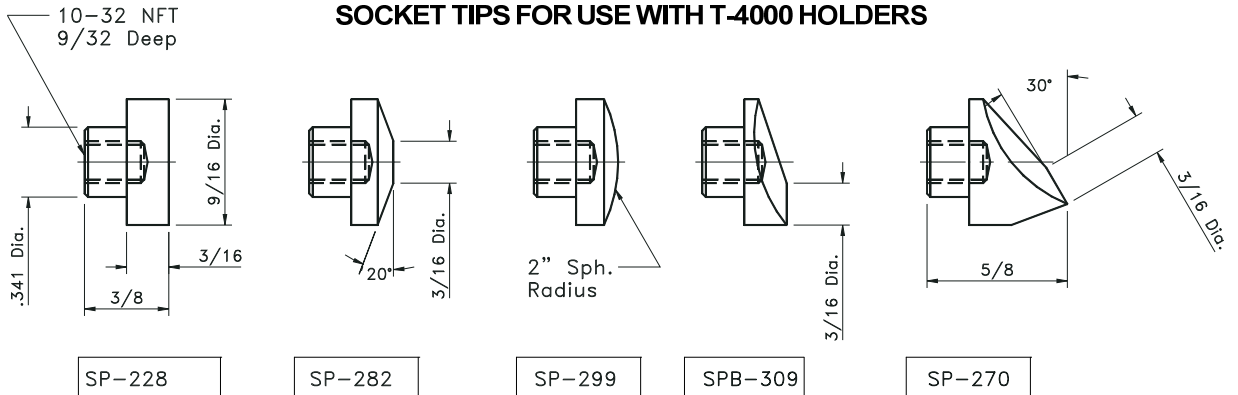



LIGHT DUTY OFFSET HOLDERS

LIGHT DUTY - 90 DEGREE OFFSET

NON-EJECTOR TYPE

4 RW
 Taper
 (#1 MT)

Part Number	Offset	Shank Diameter
T-121	2	3/4
T-122		7/8
T-123		1
T-124		1-1/4
T-131	4	3/4
T-132		7/8
T-133		1
T-134		1-1/4

5 RW
 Taper
 (#2 MT)

T-127	2	7/8
T-128		1
T-129		1-1/4
T-137	4	7/8
T-138		1
T-139		1-1/4

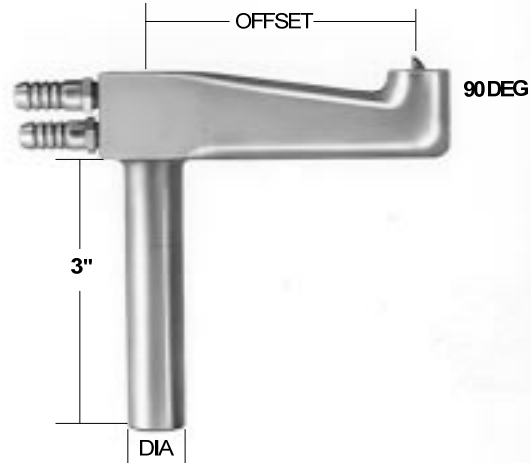

LIGHT DUTY - 30 DEGREE OFFSET

NON-EJECTOR TYPE

4 RW
 Taper
 (#1 MT)

Part Number	Offset	Shank Diameter
T-141	2	3/4
T-142		7/8
T-143		1
T-144		1-1/4
T-152	4	7/8
T-153		1
T-154		1-1/4

5 RW
 Taper
 (#2 MT)

T-147	2	7/8
T-148		1
T-149		1-1/4
T-157	4	7/8
T-158		1
T-159		1-1/4

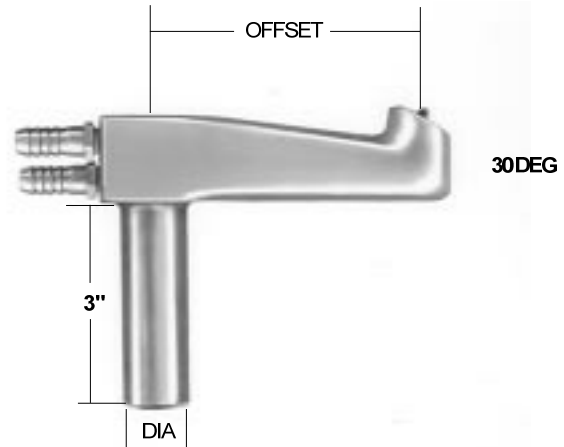

LIGHT DUTY OFFSET HOLDERS

**SPECIAL SHANK DIAMETERS, LENGTHS, AND OFFSET LENGTHS
 ARE AVAILABLE ON A MADE TO ORDER BASIS**



REVERSE OFFSET HOLDERS

REVERSE OFFSET HOLDERS

**90 DEGREE REVERSE OFFSET
HOLDERS NON-EJECTOR TYPE**

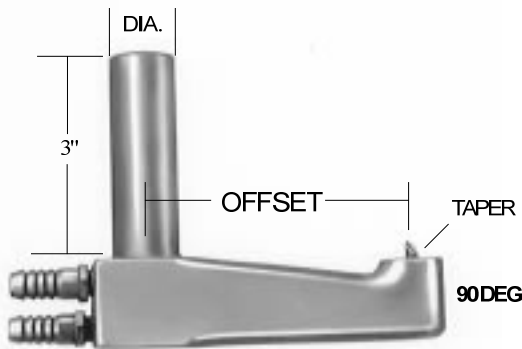

4 RW
Taper
(#1 MT)

Part Shank	Offset	Shank Diameter
T-122-R	2	7/8
T-123-R		1
T-124-R		1-1/4
T-132-R	4	7/8
T-133-R		1
T-134-R		1-1/4

5 RW
Taper
(#2 MT)

T-127-R	2	7/8
T-128-R		1
T-129-R		1-1/4
T-137-R	4	7/8
T-138-R		1
T-139-R		1-1/4

**30 DEGREE REVERSE OFFSET
HOLDERS NON-EJECTOR TYPE**

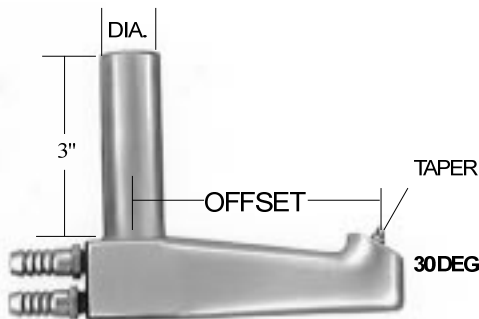

4 RW
Taper
(#1 MT)

Part Number	Offset	Shank Diameter
T-141-R	2	3/4
T-142-R		7/8
T-143-R		1
T-144-R		1-1/4
T-152-R	4	7/8
T-153-R		1
T-154-R		1-1/4

5 RW
Taper
(#2 MT)

T-147-R	2	7/8
T-148-R		1
T-149-R		1-1/4
T-157-R	4	7/8
T-158-R		1
T-159-R		1-1/4



STANDARD OFFSET HOLDERS - EJECTOR

90 DEGREE STANDARD DUTY OFFSET HOLDERS EJECTOR TYPE

Part Number	Offset	Shank Diameter
T-6700	2	3/4
T-6701		7/8
T-6702		1
T-6703		1-1/4
T-6703-A		1-1/2
T-6704	4	3/4
T-6705		7/8
T-6706		1
T-6707		1-1/4
T-6707-A		1-1/2
T-6708	2	3/4
T-6709		7/8
T-6710		1
T-6711		1-1/4
T-6711-A		1-1/2
T-6712	4	3/4
T-6713		7/8
T-6714		1
T-6715		1-1/4
T-6715-A		1-1/2

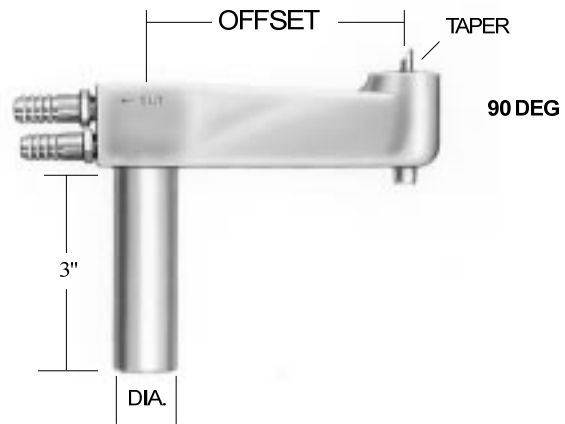

30 DEGREE STANDARD DUTY OFFSET HOLDERS EJECTOR TYPE

Part Number	Offset	Shank Diameter
T-6800	3-1/2	3/4
T-6801		7/8
T-6802		1
T-6803		1-1/4
T-6804	3-1/2	3/4
T-6805		7/8
T-6806		1
T-6807		1-1/4

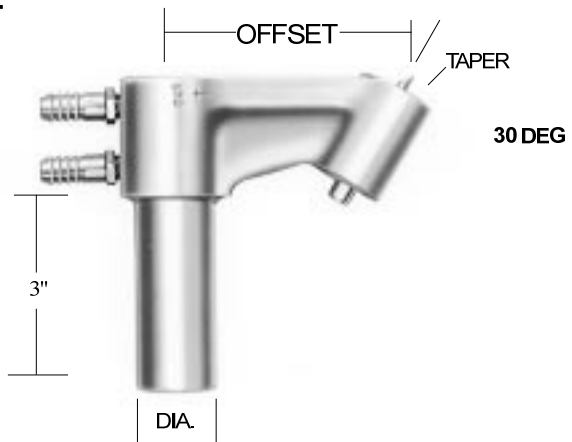

STANDARD OFFSET HOLDERS - EJECTOR



HEAVY DUTY OFFSET HOLDERS

HEAVY DUTY OFFSET HOLDERS

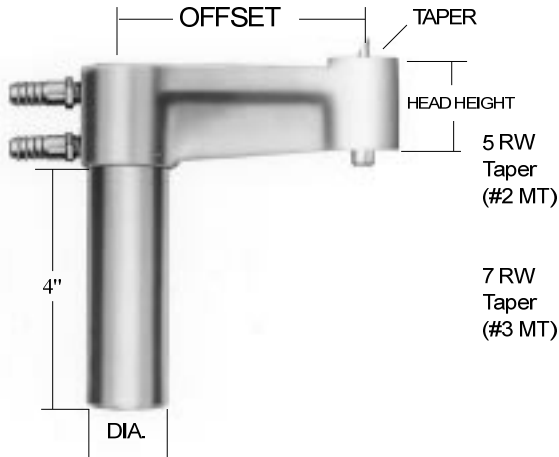

90 DEGREE HEAVY DUTY OFFSET HOLDERS EJECTOR TYPE

Part Number	Offset	Shank Diameter	Head Height
T-9021	2	1-1/4	1-7/8
T-9022		1-1/2	
T-9041	4	1-1/4	
T-9042		1-1/2	
T-9023	2	1-1/4	2-1/4
T-9024		1-1/2	
T-9043	4	1-1/4	
T-9044		1-1/2	

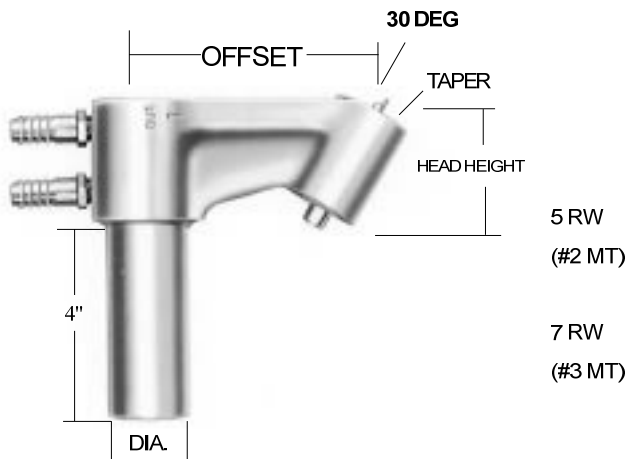

30 DEGREE HEAVY DUTY OFFSET HOLDERS EJECTOR TYPE

Part Number	Offset	Shank Diameter	Head Height
T-9341	4	1-1/4	1-7/8
T-9342		1-1/2	
T-9343	4	1-1/4	2-1/4
T-9344		1-1/2	

SPECIAL CAST AND COLD FORMED HOLDERS ARE AVAILABLE ON A MADE TO ORDER BASIS.

PLEASE CALL OR FAX WITH YOUR CUSTOM REQUIREMENTS



SPOTWELD, INC.

Excellence in Resistance Welding

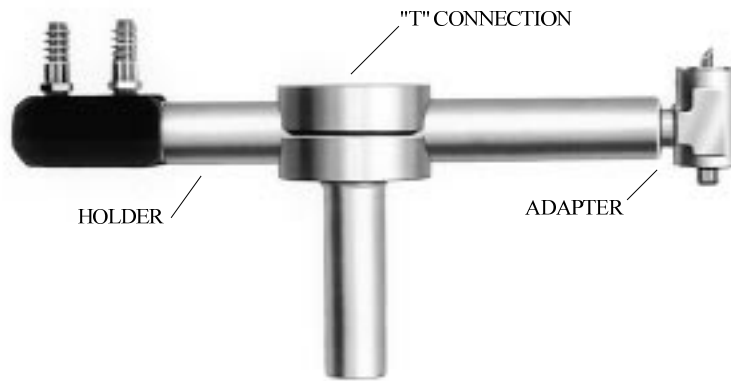

UNIVERSAL TAPERED BARREL HOLDER ASSEMBLY

ASSEMBLY PART NO.	"T" CONNECTION				HOLDER			ADAPTER HEAD			
	Part No.	Hole Dia.	Shank Dia.	Shank Length	Part No.	Body Dia.	Taper	Part No.	Angle of Head	Taper to Holder	Taper to Electrode
T-1099	T-1159	7/8	7/8	4	T-5405	7/8	5 RW Taper (#2 MT)	T-1190	90 Deg.	5 RW Taper (#2 MT)	4 RW
T-1100	T-1160	1	1		T-5406	1		T-1190			4 RW
T-1125	T-1161	1-1/4	1-1/4		T-5407	1-1/4		T-1290			5 RW
T-1200	T-1163	1	1-1/4		T-5406	1		T-1130	4 RW		
T-1250	T-1164	1	1-1/2		T-5406	1		T-1230	5 RW		



HOLDER ADAPTER HEADS

MALE TAPER TYPE

Part Number	Degree of Angle	Holder Taper	Electrode Taper
T-1190	90	5 RW	4 RW
T-1290	90	Taper	5 RW
T-1130	30	(#2 MT)	4 RW
T-1230	30		5 RW

Straight Tapered Barrel holders are shown on page 31.



"T" CONNECTIONS FOR HOLDERS

Part Number	Hole Dia.	Shank Dia.	Shank Length
T-1159	7/8	7/8	4
T-1160	1	1	
T-1161	1-1/4	1-1/4	
T-1162	1-1/2	1-1/2	
T-1163	1	1-1/4	
T-1164	1	1-1/2	
T-1165	1-1/4	1-1/2	

TAPERED BARREL HOLDER ASSEMBLIES

SPECIAL SHANK DIAMETERS ARE AVAILABLE.



SPOTWELD, INC.

Excellence in Resistance Welding

THREADED BARREL HOLDER ASSEMBLIES

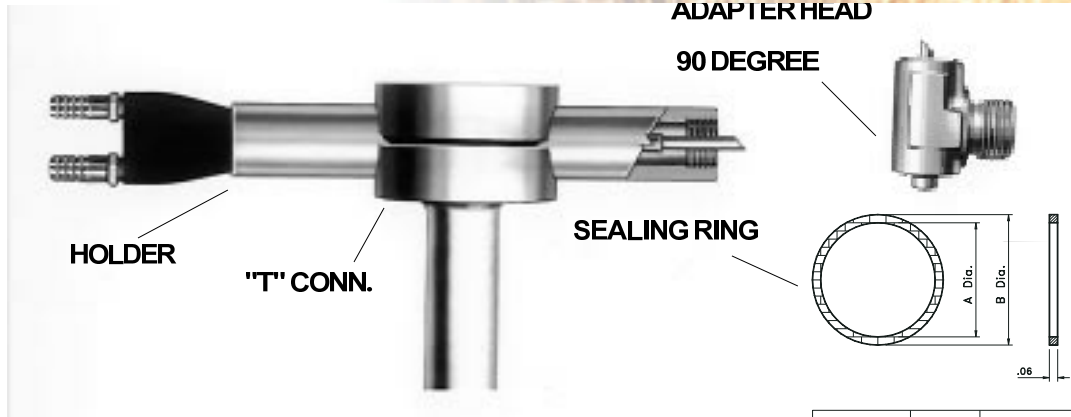

UNIVERSAL THREADED BARREL HOLDER ASSEMBLY

Part Number	A Dia.	B Dia.
760-0-0001	7/8 Dia.	1 Dia.
780-0-0001	1 Dia.	1-1/8 Dia.

ASSEMBLY PART NO.	"T" CONNECTION				HOLDER			ADAPTER HEAD				
	Part No.	Hole Dia.	Shank Dia.	Shank Length	Part No.	Body Dia.	Thread	Part No.	Angle of Head	Holder Thread	Electrode Taper	
T-2104	T-1160	1	1	4	T-5432-A	1	7/8-14	T-764	90 Deg.	7/8-14	4 RW	
T-2106	T-1160	1	1		T-5432-A	1		5 RW				
T-2114	T-1161	1-1/4	1-1/4		T-5433-A	1-1/4		4 RW				
T-2116	T-1161	1-1/4	1-1/4		T-5433-A	1-1/4		5 RW				
T-2128	T-1162	1-1/2	1-1/2		T-5435-A	1-1/2	1-14	T-778		1-14	4 RW	
T-2120	T-1162	1-1/2	1-1/2		T-5435-A	1-1/2		5 RW				
T-2105	T-1160	1	1		T-5432-A	1	7/8-14	T-780		30 Deg.	7/8-14	4 RW
T-2107	T-1160	1	1		T-5432-A	1		5 RW				
T-2115	T-1161	1-1/4	1-1/4		T-5433-A	1-1/4		4 RW				
T-2117	T-1161	1-1/4	1-1/4		T-5433-A	1-1/4		5 RW				
T-2129	T-1162	1-1/2	1-1/2		T-5435-A	1-1/2	1-14	T-779	1-14		4 RW	
T-2121	T-1162	1-1/2	1-1/2		T-5435-A	1-1/2		5 RW				

STRAIGHT THREADED BARREL HOLDERS



90 DEG

Part No.	Barrel Dia.	Barrel Length	Barrel Thread
T-5432-A	1	8	7/8-14
T-5433-A	1-1/4		
T-5434-A	1-1/2		1-14
T-5435-A	1-1/2		

90 DEGREE HOLDER ADAPTER HEADS MALE THREAD TYPE



30 DEG

30 DEGREE HOLDER ADAPTER HEADS MALE THREAD TYPE

Part Number	Degree of Angle	Holder Thread	Electrode Taper
T-764	90	7/8-14	4 RW
T-766			5 RW
T-778		1-14	4 RW
T-780			5 RW

Part Number	Degree of Angle	Holder Thread	Electrode Taper
T-765	30	7/8-14	4 RW
T-767			5 RW
T-779		1-14	4 RW
T-781			5 RW



SPOTWELD, INC.

Excellence in Resistance Welding

SPRING LOADED HOLDERS



IMPROVE THE QUALITY OF PROJECTION TYPE WELDS
AND WELDS ON MATERIALS WITH LIMITED PLASTIC RANGES

Tipaloy's low inertia (fast follow-up) holders are designed for easy maintenance. Adjustments for different pressure ranges can be made by simply changing the external spring. Taper changes are made by replacing the threaded adapter.

A solid electrical connection is ensured on all current carrying members through the use of clamp and bolted connections good for the life of the product. There are no sliding type connections which can create wear related problems.

These units can be ganged together for multiple spot or projection welding applications. For use with offset electrodes, add "NR" at the end of the part number for a non-rotating holder.

The T-3300 Series holders are supplied ready to use. Simply add your electrodes. Each unit is supplied with a DFF-600MCM-12" cable, a stationary and sliding water tube, and either an AP-H24B-7 (4 RW) or AP-H25B-7 (5 RW) threaded adapter. Other cables and adapters are available at an additional cost. Each unit is supplied with complete instructions for optimum use.

Please call Tipaloy for additional information on our low inertia holders or any of your resistance welding requirements.

SPRING LOADED HOLDERS

(LOW INERTIA)

Part Number	Barrel Dia.	Taper
T-3314-*	1	4 RW
T-3324-*	1-1/4	Taper
T-3334-*	1-1/2	(#1 MT)
T-3315-*	1	5 RW
T-3325-*	1-1/4	Taper
T-3335-*	1-1/2	(#2 MT)

* Specify one of the following:

4	= 400 Pound Spring
7	= 700 Pound Spring
10	= 1,000 Pound Spring

NOTE - For a non-rotating unit for use with offset tips, add "NR" at the end of the part number when ordering.

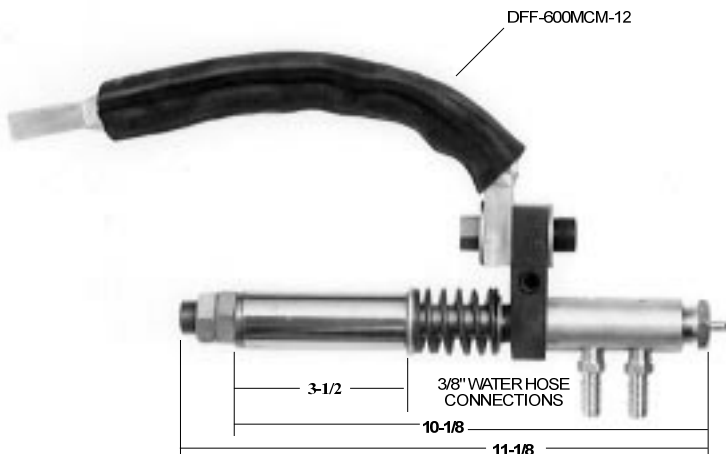

SPRING LOADED HOLDERS



SPOTWELD, INC.

Excellence in Resistance Welding

WELD GUN CYLINDER HOLDERS

- *Designed for air and hydraulic guns and cylinders on resistance spot welding equipment.
- ***Individual supply of water and current** to each holder for better weld quality.
- ***Silver plated** barrel and clamp for higher conductivity and corrosion resistance.
- *Available for **4 RW, 5 RW, 6 RW, and 7 RW** taper electrodes.
- *When ordering, specify assembly size as shown below.
- ***To complete your set-up**, order hose barbs, adapters, stationary water tubes and sliding tubes to suit your specific requirements.
- ***Replacement parts may be ordered individually**

T-101

Barrel and Clamp Assembly
For 4 RW and 5 RW Electrodes

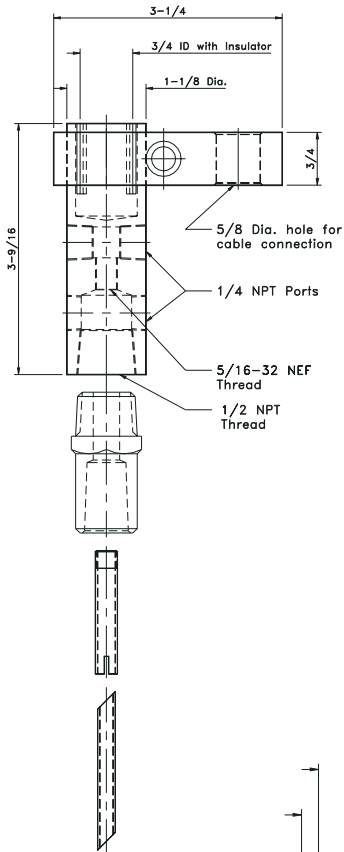

T-102

Barrel and Clamp Assembly
For 6 RW or 7 RW Electrodes

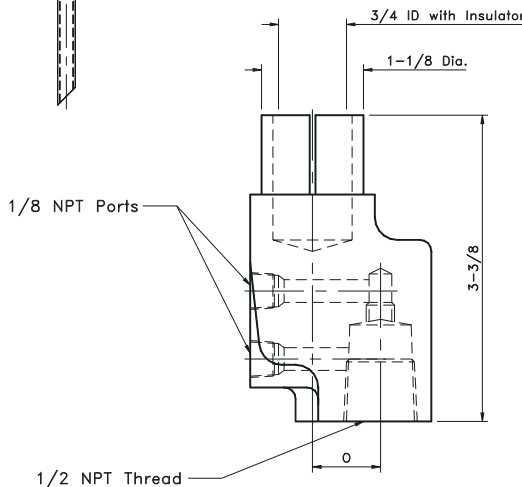
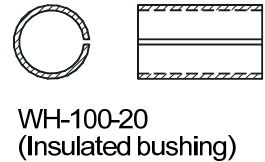
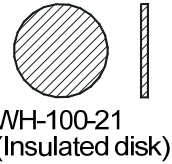
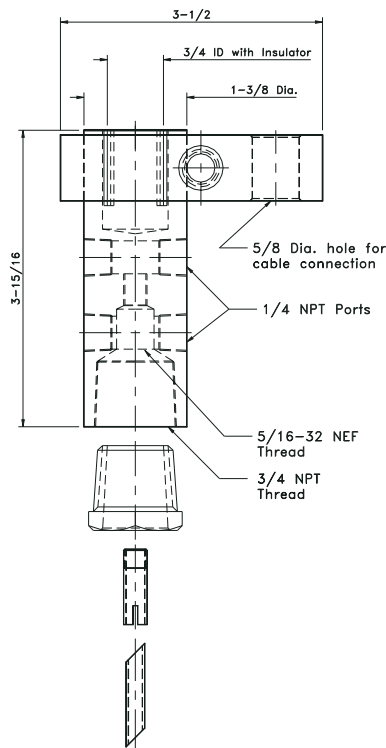

OFFSET HOLDERS

Part No.	Offset
	0
T-101-.50	1/2"
T-101-.75	3/4"
T-101-1.0	1"

OPTIONS

- *Additional offsets
- *#6 & #7 RW Tapers
- *3/4 NPT water connections



WELDING GUN CYLINDER HOLDER COMPONENTS

ELECTRODE ADAPTER SELECTION CHART

Adapter Length
7/8
1
1-1/4
1-3/8
1-1/2
2
2-1/2
3

T-101 size Adapters 1/2" NPT	
4 RW Taper	5 RW Taper
AP-H24B-7	AP-H25B-7
AP-H24B-8	AP-H25B-8
AP-H24B-10	AP-H25B-10
-	-
AP-H24B-12	AP-H25B-12
AP-H24B-16	AP-H25B-16
AP-H24B-20	AP-H25B-20
AP-H24B-24	AP-H25B-24

T-102 Size Adapters 3/4" NPT	
6 RW Taper	7 RW Taper
-	-
-	-
-	-
AP-H36D-11	AP-H37D-11
AP-H36D-12	AP-H37D-12
AP-H36D-16	AP-H37D-16
AP-H36D-20	AP-H37D-20
AP-H36D-24	AP-H37D-24

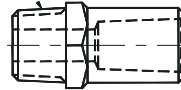
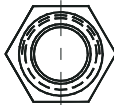
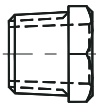

STATIONARY WATER TUBES

Part Number	Length
DS-5-3	3/4
DS-5-4	1
DS-5-5	1-1/4
DS-5-6	1-1/2
DS-5-8	2
DS-5-10	2-1/2

SLIDING WATER TUBES

Part Number	Length
DF-4-4	1
DF-4-5	1-1/4
DF-4-6	1-1/2
DF-4-8	2
DF-4-10	2-1/2
DF-4-12	3
DF-4-16	4

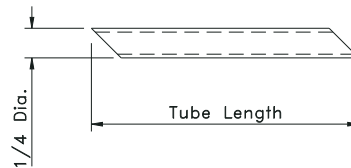
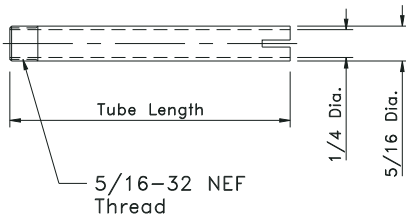

HOW TO ORDER:

T-101 Tubes for use with 4 RW Adapters -

ORDER STATIONARY TUBE AT LEAST 1/4" SHORTER THAN ADAPTER LENGTH.

T-101 Tubes for use with 5 RW Adapters -

ORDER STATIONARY TUBE 1/2" LONGER THAN ADAPTER FOR TUBE TO BE FLUSH.

T-102 Tubes for use with 6 RW or 7 RW Adapters -

ORDER STATIONARY TUBE 3/4" LONGER THAN ADAPTER FOR TUBE TO BE FLUSH.

SLIDING TUBES SHOULD BE ORDERED AT LEAST 1/2" LONGER THAN WATER HOLE DEPTH OF TIP BEING USED.



T-185-AC PNEUMATIC ELECTRODE DRESSER

- *Light Weight (1-3/4 lbs.) - Designed for Electrode Dressing at the Work Station
- *Variable Speed to 1,500 RPM
- *Operates on 60 PSI Air Pressure, (70 - 100 PSI is Recommended)
- ***Saves You Money in Electrode Dressing Time and Improves Weld Quality by Maintaining Proper Weld Face Diameters.**



T-195-AC AUXILIARY DRIVE UNIT

- *3,000 RPM Maximum
- *Designed to be driven by auxiliary power.
- *3/8" Hex Drive Extension on rear of unit allows you to select your method for driving the unit.



CLEARANCE DIMENSIONS

Flush Cutters have an overall height of 1". Extended Cutters have an overall height of 1.475". The diameter of the dresser head is 1.825".

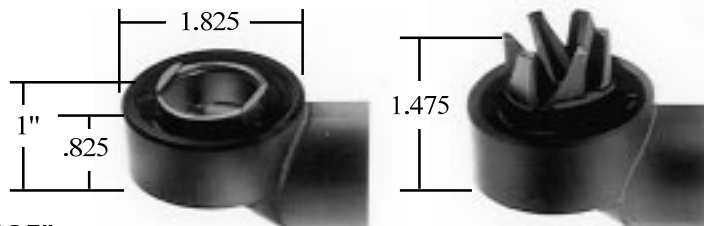

PNEUMATIC TIP DRESSERS



SPOTWELD, INC.

Excellence in Resistance Welding

FLUSH TYPE STRAIGHT

FLUSH TYPE TAPERED



For No. 4RW Electrodes
Use chuck No. C-6 for all.

For No. 4RW Electrodes
Use chuck No. C-3 for all.

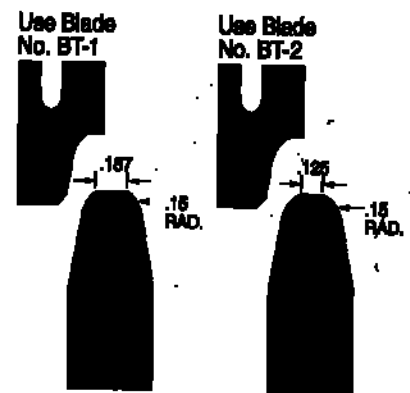
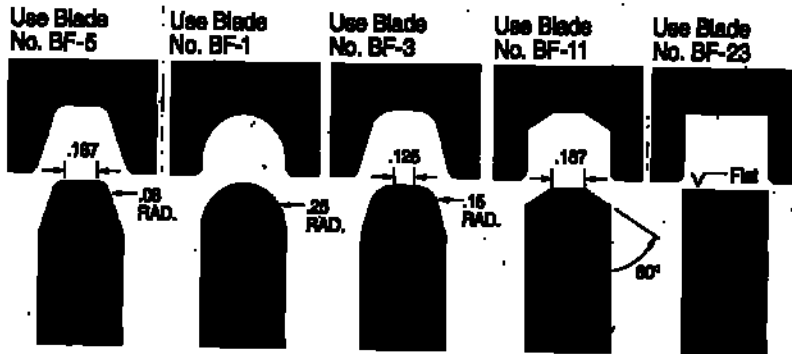

For No. 5RW Electrodes
Use chuck No. C-5 for all

For No. 5RW Pointed Electrodes
Use chuck No. C-4 for all

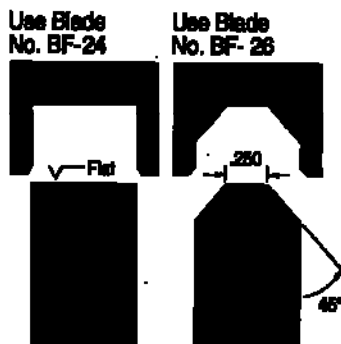
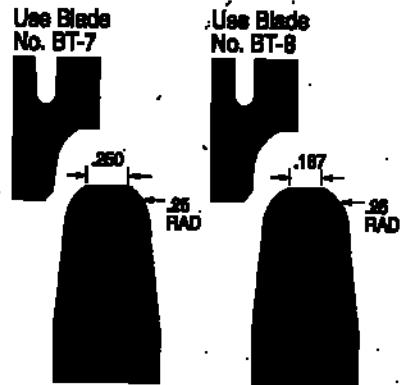
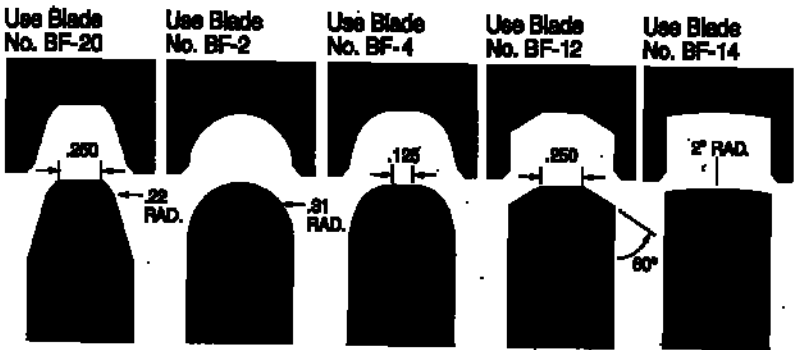

Solid Style Cutters, 1 Piece
For M & 5RW Electrodes

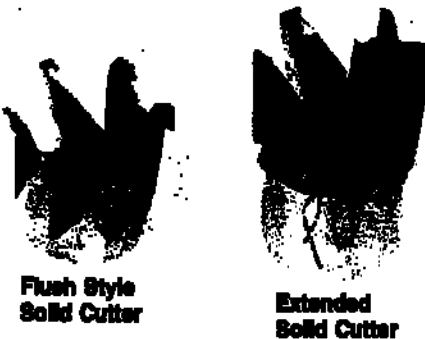

Lathe or Drill Press
Adaptor

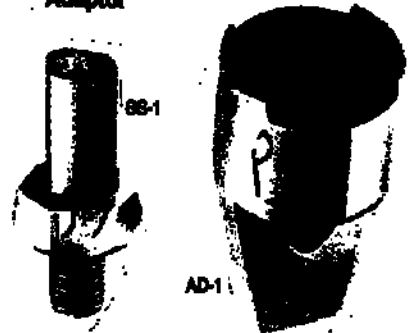

TIP DRESSING BLADES & CHUCKS



SPOTWELD, INC.

Excellence in Resistance Welding

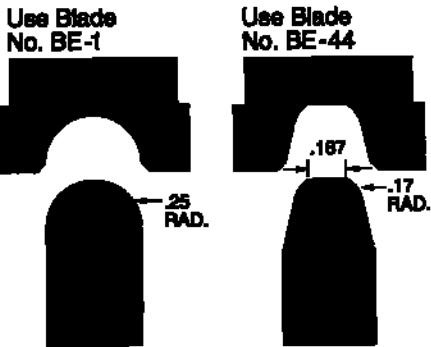

Table Dresser

This off-line table dresser is perfect for high production redressing of cap tips. This machine will accommodate both male and female caps (with available tooling)

PART # DT-1

For No. 4RW Electrodes
Use Chuck No. C-1; Nut N-1, Ring No. R-2



For No. 5RW Electrodes
Use Chuck No. C-1; Nut N-1, Ring No. R-1

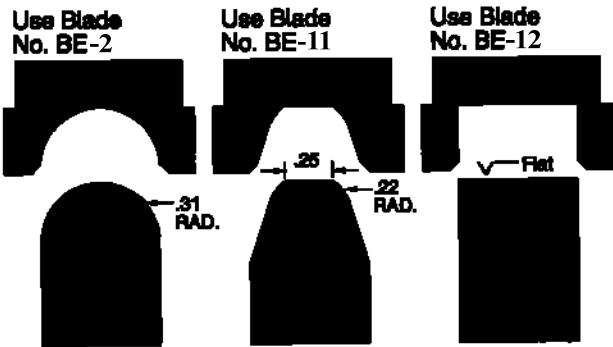

For No. 6RW Electrodes
Use Chuck No. C-2; Nut N-2

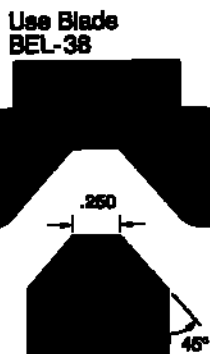
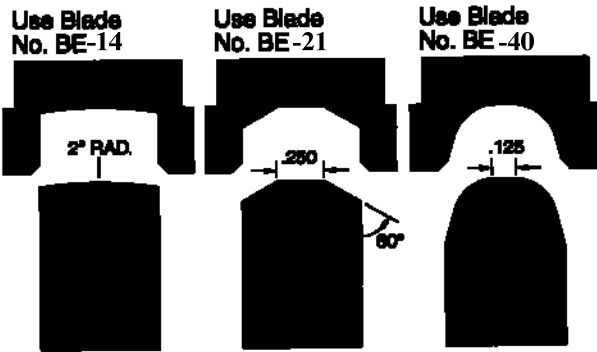
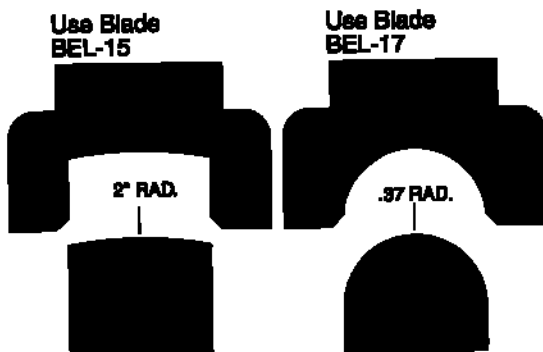

For No. 7RW Electrodes
Use Chuck No. C-2; Nut N-3

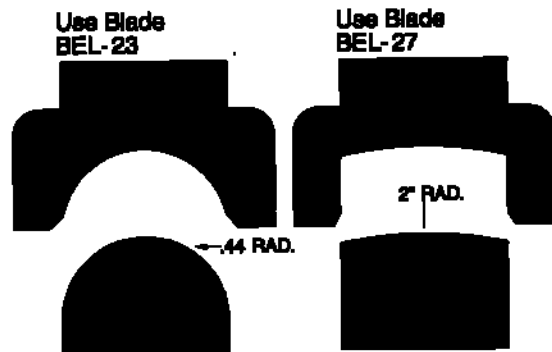

TIP DRESSING BLADES & CHUCKS



SPOTWELD, INC.

Excellence in Resistance Welding

ACCESSORIES



MALE CONNECTIONS

Part No.	Connection
601-AC	1/8" MPT
603-AC	1/4" MPT



NON-CONDUCTIVE WATER HOSE

Part No.	Color
T-320-AC	RED
T-320-AC BLACK	BLACK
T-320-AC GREEN	GREEN



MALE CONNECTIONS

Part No.	Connection
01-AC	1/8" MPT
03-AC	1/4" MPT



FEMALE CONNECTIONS

Part No.	Connection
600-AC	1/8" FPT
602-AC	1/4" FPT



UNION STEMS

Part No.	Connection
T-201-AC	for 3/8" Hose



HOSE STEM CONNECTIONS

Part No.	Connection
07-AC	1/4" Hose Stem
09-AC	3/8" Hose Stem



HOSE STEM CONNECTIONS

Part No.	Connection
606-AC	1/4" Hose Stem
607-AC	5/16" Hose Stem
608-AC	3/8" Hose Stem



HOSE CLAMP

T-321-AC



WATER NIPPLES

For Standard 3/8" Hose

Part No.	Thread Size
5600-6-0323	1/8" NPT
T-324-AC	1/4" NPT



SPECIAL TAPER REAMERS

FOR HOLDERS

Part No.	Taper Size
----------	------------

STANDARD ELECTRODE TAPERS

T-300-AC	Morse Electrode
T-301-AC	4 RW (#1 MT) Electrode
T-302-AC	5 RW (#2 MT) Electrode
T-303-AC	7 RW (#3 MT) Electrode

CAP TIP TAPERS

T-304-AC	4 RW (#1 MT) Cap
T-305-AC	5 RW (#2 MT) Cap
T-306-AC	6 RW Cap
T-307-AC	7 RW (#3 MT) Cap

These reamers provide an economical way of restoring worn tapers to their original cap tip or electrode taper socket size.

Special reamers, including 8 Degree, are also available.



ACCESSORIES

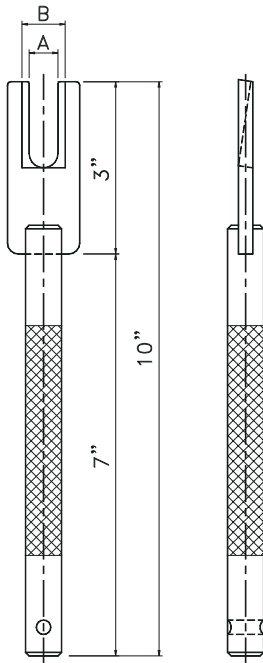

FORK TYPE EXTRACTORS

Part No.	Male cap Taper Size	Female Cap Taper Size
T-314-AC	4 RW & 5RW	4 RW
T-315-AC	6 RW	5 RW
T-316-AC	7 RW	6 RW & 7 RW



PLIER TYPE EXTRACTOR

Part No. T-380-AC



TIP EXTRACTOR

Part No. 250MM Speed Wrench



RATCHET STYLE DRESSER

Assembly Part No.	T-361-AC-B
Replacment Cutter Part No.	T-361-AC



2" RADIUS TIP FILE

Part No.	T-381-AC
Handle No.	GRA-05

ACCESSORIES



SPOTWELD, INC.

Excellence in Resistance Welding

T-360U SERIES MULTI-SPOT HOLDER

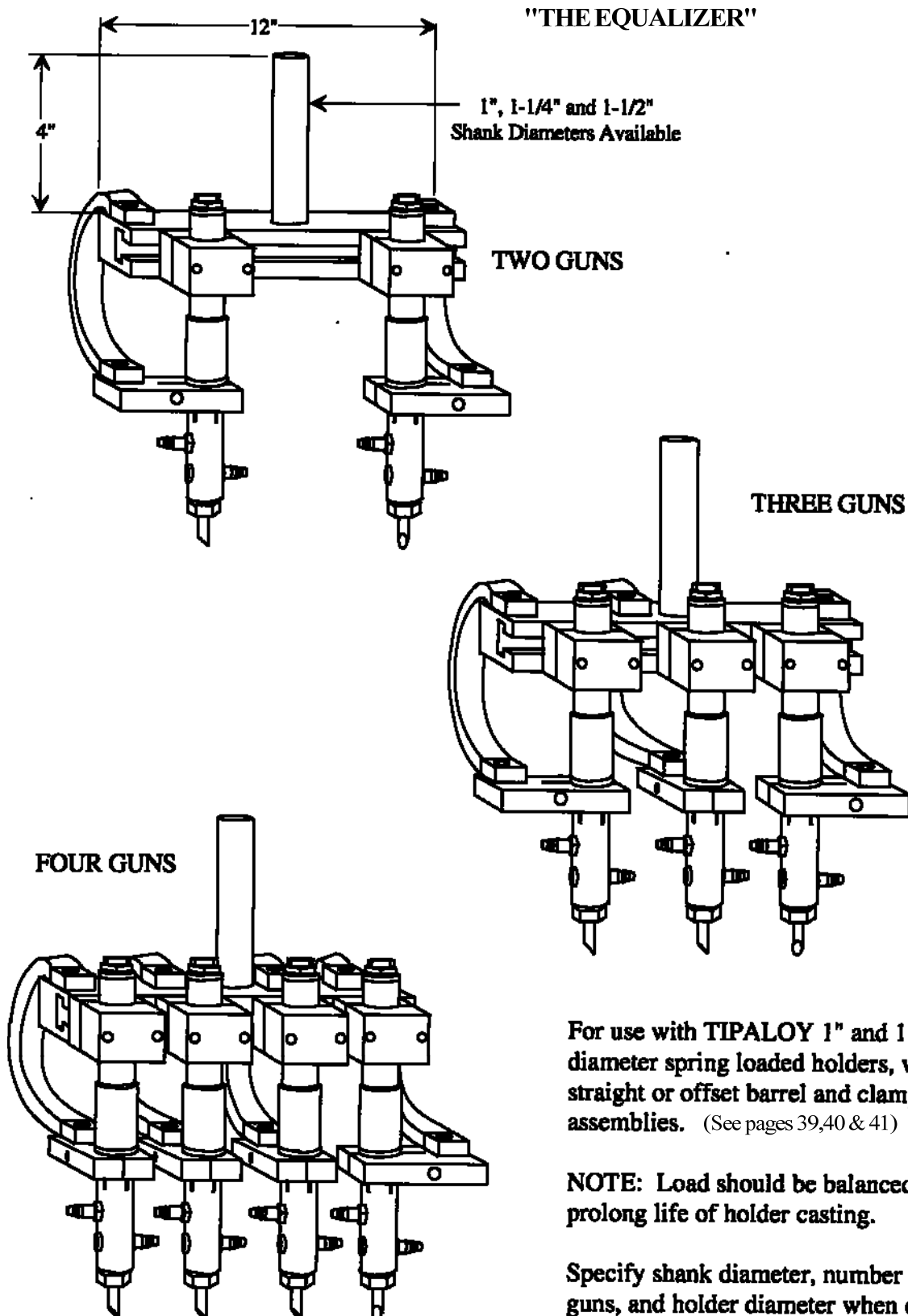

TIPALLOY EQUALIZER

For use with TIPALLOY 1" and 1-1/4" diameter spring loaded holders, with straight or offset barrel and clamp assemblies. (See pages 39,40 & 41)

NOTE: Load should be balanced to prolong life of holder casting.

Specify shank diameter, number of guns, and holder diameter when ordering.